

## INSIDE THIS EDITION

### IN THE NEWS

Pages 1-7 → [Fares Revision Review](#)  
 → [POM Stickers](#) → [POM Problems](#)  
 → [NR Ticketing changes](#)

### PROJECT UPDATES

Pages 14-19 → [POM upgrades](#) → [Data routing changes](#) → [LCP3 upgrade](#)

### SPECIAL FEATURE

Pages 8-9 → [Keeping An Eye on the Neighbours](#) → [May Fraud Survey](#)

### AND FINALLY

Page 20 → [Crimewatch Update](#) → [Looking Ahead to TRUI04](#)

### OYSTER EXPLAINED

Pages 10-11 → [Emergency Gate Settings](#)

TRIVIA — Pages 1, 5 & 15  
 Answers on Page 19

### ASK OLLY!

Pages 12-13 → [Your letters answered](#)

[Click here](#)



← Many articles now have embedded links allowing iPad or PC users easy access to useful documents and articles. Simply click or touch on each link to activate.

# TICKETING APP GETS UPDATED

In our lead article of [TRUI02](#), we announced the forthcoming launch of the new TfL Ticketing app at the end of August.

Shortly after publication, it was announced that the public launch would be delayed until after the September Fares Revision and the app eventually went live on **Friday 08 September**.

TfL have since announced plans to expand the Faster Universal Load (FUL) facility and the functions offered by the app during October, to include buses. The changes will be made in three stages:



FUL will become available on buses for the first time. For customers topping up or buying a Travelcard season ticket via the Oyster website.

As with the current FUL facility on LU devices, the customer should be able to collect their product 30 minutes after completing their purchase.

Bus & Tram Season tickets will be available via the website and will again be available to be collected after 30 minutes on a bus, tram or when making a journey via any LU or rail station.



### Page 19 [FIRST LOOK AT THE NEW SCU](#)

We give you a first preview of the new LU touchscreen SCU being developed by Cubic and preparation for the deployment of these new units next year.

### Page 10 / 11 [EMERGENCY GATE SETTINGS](#)

As this month's Oyster Explained topic we revisit the subject of Emergency Gate Settings and how they work.

### Page 4 [NOTE ACCEPTANCE PROBLEMS](#)

We follow up on note handling problems since the introduction of the polymer £5 note last year and update you on the latest work to address these issues.

### Page 3 [POLYMER £10 NOTES ARE HERE](#)

After lots of preparation, the Bank of England has recently launched the new style £10 note, we provide details of the launch of polymer £10 notes by the 3 Scottish banks and on Page 16 we cover the upgrade of CHDs to handle these.

### Pages 16 [CHD UPDATES](#)

We update you on a couple of recent changes which are now being made to the CHD and the first use of a remote upgrade of some of the devices.

Products or top-ups purchased directly via the app will be available to be collected via the Oyster reader on any bus, 30 minutes after completion, in a similar manner to website purchases.



Written and compiled by

**ALAN MUNDY & DAVID NIX**



The latest fares revision which took place on **Sunday 03 September** went extremely smoothly. For the first time in memory there were no devices across the whole Oyster network that failed to correctly load their new fare tables.

It probably therefore ranks as one of the most successful fares revisions we have had. On LU the upgrades to devices over the last year or so, particularly the AFM PC replacement, has eliminated the issues that we had previously seen, with devices struggling to handle the downloading of large tables associated with fare and customer screen changes.

The only issue that was reported on the Sunday involved the Portable Ticketing Devices (PTIDs) used on certain Thames River Boat services and by Conductors on the Route 15 Heritage bus service. These devices failed to work after being docked to load the new base table for the fares revision.



Cubic arranged for engineers to attend West Ham garage on the Sunday evening and on the Monday morning before the first of the affected River Services were due to operate, to temporarily load replacement PTID's with pre-September fares revision tables so that they could be used. There was no impact to customer fare charging as a result of this fix being temporarily applied. The correct September base data was then successfully loaded to all devices by **Tuesday 05 September**, enabling the fares revision deemed to be completed successfully and the change freeze to be lifted.

One other issue identified following the fares revision affected the TfL Single Fare Finder app on the intranet, which was not updated to show the revised prices for journeys that were changed on **03 September**, until a couple of days after the fares revision. As a result, anyone checking fares for the affected journeys would have potentially been given out of date information. This issue has now also been resolved.



The changes to some NR fares and Travelcards valid to Watford Junction mean that a new set of Staff Fares Lists have been issued. These can be printed locally from a SharePoint site accessible to LU operational staff and can be saved to personal or shared drives or onto an iPad for future reference. To access the SharePoint site [click here](#).

## ALL CHANGE AT T&D

As part of the ongoing restructuring of what was known as Customer Experience, into the new Technology & Data team, we have seen a number of changes of personnel and the relocation of the team.



From **14 August** the sections of Technology & Data covering ticketing and related activities were relocated from Windsor House in Victoria Street to join their former IM colleagues at 14 Pier Walk in North Greenwich.

The changes also saw re-designation of the former CE Helpdesk emails for the Service Desk, device escalation and technical support amalgamated into one new email address:

[TDOperationsCentre@tfl.gov.uk](mailto:TDOperationsCentre@tfl.gov.uk)

**T&R Book Appendix 4 – Useful T&R Contacts** has been updated to reflect these changes and is available to view or download from the T&R Intranet pages or by following the link provided below;

[http://luintranet.tfl/static/documents/coo/Appendix\\_4.pdf](http://luintranet.tfl/static/documents/coo/Appendix_4.pdf)

## NLCs & FARE ZONES

**T&R Book Appendix 2** has also been updated following the September fares revision and is available to view or download from the T&R Intranet pages or by clicking on the link below;

[http://luintranet.tfl/static/documents/coo/Appendix\\_2.pdf](http://luintranet.tfl/static/documents/coo/Appendix_2.pdf)

Updates include;

- **New NLC for Victoria (District)**
- **Inclusion of the River Pier NLC's for East, Central and West Zones**
- **Addition of the Lea Bridge NLC**
- **Correction to the Grays NLC**

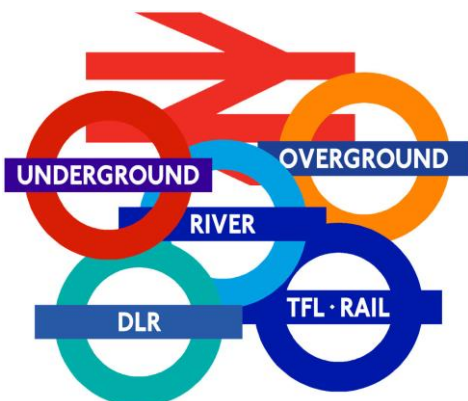

## POM STICKERS

After a very lengthy wait since our first request for a sticker to highlight non-acceptance of £50 notes on MFMs with BNR units, a sticker is now being rolled out to all MFMs.

The sticker isn't exactly what we were looking for and doesn't include an image of the £50 note as suggested by staff at the affected stations. However it does indicate in number format the denominations of note accepted and via a / through the £50, that this denomination is not accepted by the device.



The new stickers are a replacement for a previous design of "Notes Here" sticker developed for the BNR and subsequently deployed to other MFMs to highlight to customers that it was not the place to insert their bankcard.



The new stickers are being fitted by Cubic engineers during visits to stations to perform the coin and note upgrades, as outlined in [Page 15](#).

Once fitted any locally produced £50 note stickers or paper notices which had been applied to devices as a stop gap measure, should be removed.

Towards the end of September the T&R team are due to receive a further batch of the bankcard scheme acceptance stickers, which were deployed as the new Chip & Pin units (PEDs) were installed.

We are aware of a number of stations where these were either missed, have been removed or in some cases have become badly scratched. We are hopeful that the new design will be more resilient like other POM stickers.



Missing or damaged POM or gateline stickers should be reported to the T&R Team [click here](#). Please remember to state which devices require the stickers and the type required.

## £10 POLYMER NOTE

One year and one day on from the launch of the first £5 polymer banknotes the Bank of England launched the new £10 polymer banknote on **Thursday 14 September 2017**.

The new notes, featuring novelist Jane Austen on the reverse (2017 marks the 200th anniversary of her death) are smaller than the outgoing "Darwin" notes, but comprises the same robustness and advanced security features as that of the new fiver. Existing paper £10 notes will be withdrawn as they are banked, but will continue to be legal tender until a date to be announced in the Spring of 2018.

As happened with the £5 note, the Scottish banks plan to launch their versions of a polymer note within a month (see table below).



SCOTTISH BANKS £10 NOTES LAUNCH DATES		
	<b>CLYDESDALE</b>	<b>21 September</b>
	<b>ROYAL BANK OF SCOTLAND</b>	<b>04 October</b>
	<b>BANK OF SCOTLAND</b>	<b>10 October</b>

Bank Note Recyclers (BNR) and Bank Note Acceptors (BNA) in MFMs and CHDs have been upgraded to accept the new notes and customers and staff should not notice any difference in how these devices operate. On BNR units paper notes will be given as change in preference to polymer banknotes until devices are upgraded in October.

Any polymer notes returned by any CHD note acceptors should be fed back into the machines in the same way a 'difficult' paper note currently is and any faults with devices should be reported in the usual manner.

## MFM – NOTE PROBLEMS CONTINUE

Over the last few months we have had a steady stream of correspondence from stations relating to issues with note handling on the MFM.

In [TRUI01](#) we provided an update on MFM Reliability, which included some details on what was being done to try and alleviate the problems with note acceptance on these devices.

With the recent introduction of the new polymer £10, we thought it would be timely to update readers on what is being done to improve performance and reduce the numbers of note jams and failures we have been seeing. At the time of going to print, it is probably a little too early to gauge the impact of the new £10 notes, as although they are now in circulation; the vast majority of £10 notes in use are still the older paper versions.

Although not exclusively a problem on the older Bank Note Acceptor (BNA) units, we currently seem to be having fewer issues reported from stations where the MFMs are fitted with a Bank Note Recycler (BNR) and some of this is being attributed to a software fix which was rolled out as part of the recent MFM software upgrade.

On the BNA units, Cubic have recently identified a couple of problem areas, involving an “O” ring belt located at the point the note is inserted into the device. Wear on this component has been seen to cause the note to skew to one side as it is inserted, rather than going in straight and is likely to then cause a jam further in the mechanism or if the device attempts to reject the note. A similar issue has also been seen with a belt located near the note vault.



To try and alleviate this issue, Cubic have changed the frequency at which these components are changed within their workshop from after 100,000 notes have been processed to now being changed after 50,000 notes have been processed. This will only happen once a BNA unit is changed and returned to the workshop, but should in future avoid the situation we have seen at a couple of sites, where a BNA unit has been changed, but the replacement actually had completed more note cycles than the original unit and was therefore more likely to fail with this a particular issue.

When in the ticket hall assisting customers to use the POMs, please pay particular attention to how the MFM is taking the notes in through the mouth of the note acceptor and if you see the notes skewing to one side, please report this to the Cubic Helpdesk (Auto 1610) as a fault.

One other area that has recently caused some confusion is around whether an individual note jam should be reported as a fault, or whether it should be just cleared by performing a service or reset of the device. So to clarify, responsibility for the first level of maintenance/fault clearance on all devices sits with LU operational staff to complete. In the case of note jams, it is particularly important to attempt to clear the jam, so that the device is fully available to customers and in cases where a customer has lost money in the device, the appropriate tender can be recovered and the customer refunded or be issued with the product they required.

A job should be reported to Cubic if;

- ***Having attempted to clear the jam and performed a couple of resets, the device continues to show a note jam***
- ***There is a recurring pattern of note jams within a shift – in such cases it should be reported as “Recurring note failure,” rather than a one off event***
- ***If the device fails with a further note jam immediately after closure of a previous job.***

Feedback from a number of stations recently has highlighted unacceptable levels of note jams on certain devices. However, when we have investigated these with Cubic, in a number of cases we have found that very few faults had actually been logged with Cubic.

This may be down to staff either being keen to fix the device and return it to service as soon as possible or in some cases taking a high level of failures as “the norm” and therefore feeling it isn’t worth reporting them. Unfortunately a side effect of this is that the measurements of device performance on which Cubic are paid, may not necessarily reflect the performance we are actually seeing across the network.



## END OF THE ROAD FOR ROUND POUND

Just a final reminder that the old design of £1 coin will cease to be legal tender after **Saturday 14 October 2017**. Don't worry if you have a jar or piggy bank containing examples of these, as for a period, you should still be able to exchange them at banks.

It looks likely that a small number of our MFM's will not have received their final updates to prevent acceptance of the paper £5 and old pound coin before **14 October**. The last of these devices are scheduled to be completed on **Monday 16 October**, so at these sites there is a small chance that during the final couple of days of the programme, a customer may insert an old £1 coin into the MFM and for this to be accepted and subsequently dispensed as change to another customer.

To mitigate against this, in the week before the £1 coin is withdrawn special instructions will be sent to the small number of stations which could potentially be affected.



As outlined in our update on changes to the Cash Handling Device (CHD) on **Page 16**, all of our CHDs will have been updated to reject any old £1 coins accepted by the MFM and these will need to be banked separately to the new design of £1 coin.



## BE PATIENT - YOUR TICKET IS ON THE WAY!

We have had an unprecedented level of device and software changes over the last year and recent testing has highlighted a couple of new issues that appear to have been introduced by a recent change.

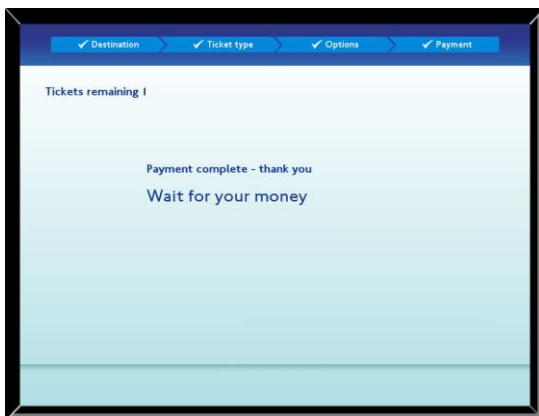

The most notable issue involves MFM's with a BNR.

Staff at **Euston** initially highlighted a very long delay between a customer receiving a note as part of an Oyster refund transaction.

A period of almost 30 seconds then elapsed before the remainder of their refund was dispensed in coin.

The same excessive delay has since also been observed on ticket or Oyster purchases where change is dispensed. In the case of multiple ticket purchases, the first ticket and note are dispensed quickly and there is then a long delay before the remaining tickets and the rest of the change is dispensed in coins.

There is obviously a risk that an unfamiliar customer may have walked away in the meantime.

To clarify - This issue only occurs where the MFM dispenses a combination of notes and coins as change or as part of a refund.

This is currently being followed up with Cubic, to identify the reason why this long delay is now occurring and hopefully to deploy a fix to resolve the issue as soon as possible.

**Part 2 – How time flies! The AFM has just had a recent birthday...**

**Q2) ... but what milestone has it reached since the first installation?**

**A** 5 Years

**B** 10 Years

**C** 15 Years

**D** 20 Years

**Q3) ... and where were the very first AFMs installed?**

**A** ASHFIELD HOUSE

**B** EMBANKMENT

**C** CANARY WHARF

**D** RODING VALLEY



**Ticketing & Revenue**  
**T&R**  
Trivia

[Answers on Page 19](#)



# IN THE NEWS...

## OYSTER PHOTOCARD REISSUE

It is that time of year again. The nights are drawing in, schools and universities have started their new academic years and we will be seeing the large scale reissue of Oyster Photocards.

11-15, 16-17 and 18+ Oyster Photocards expire on **30 September** and holders have a short period at the start of the academic year to apply for their new card. The issue of new Oyster Photocards also means a spike in demand to have discounts added to the new cards.

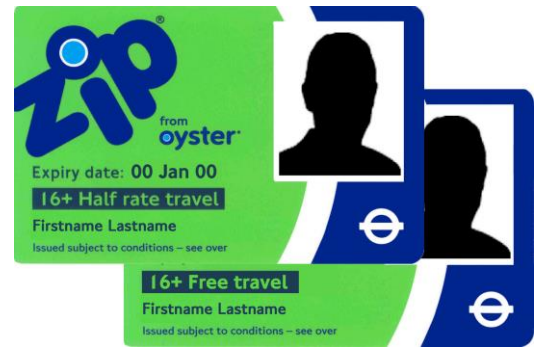

Procedures for adding discounts are contained within **T&R Book 2 Sections 4 & 5**, but there are a couple of issues we would like to highlight.

- *When adding a discount to an Oyster Photocard, take care not to overwrite any existing discounts in slot 1, as this may interfere with the holders free travel entitlements.*
- *Priv NR only discount entitlement for NR staff with red TOC only PTACs cannot be set at any LU stations.*
- *Holders of 16-17 Zip cards who want the restricted TfL Rail only discount added must obtain a separate Oyster for their Priv discount, as the TfL Rail discount is incomparable with the other entitlements on the card. This is due to the fact that privilege rate applies to journeys on TfL services, but half adult rate would apply on NR journeys. This causes a problem on through journeys starting at an LU station, but ending at a NR station or vice versa.*



This does not affect holders of unrestricted 'Priv All Rail' PTACs who can have their privilege discount loaded onto their Oyster Photocard as there is no conflict between their discounts.

## DIGITAL RAILCARD FEEDBACK

Following the introduction of Digital railcards, which we featured in [TRUI01](#) the Rail Delivery Group are very keen to receive feedback from staff regarding how they have interacted with the customer app and what they think of it in general.

# Rail Delivery Group

There are two ways in which feedback can be provided;

- The first (recommended) option is through an online survey hosted via [surveymonkey \(click here\)](#)
- The second option is via an email to the [T&R Team \(click here\)](#), which we will forward to the RDG. If this option is chosen, staff are asked to consider the key questions provided below;



1. Thinking about when the customer showed you their Railcard
  - Was the type of Railcard clear (e.g. 16-25)?
  - Was the customer able to show the digital Railcard quickly & easily? (e.g. did the app load quickly, did the customer know which screen to show)
  - Was the photo of the customer clear?
  - Was the photo a good likeness?
  - If you scanned the barcode, was this quick and easy to do?
  - Was the expiry date clear?
2. The digital Railcard has a reactive National Rail double arrow hologram that moves when the phone moves.
  - Did you notice the reactive hologram security feature?
  - Was the reactive hologram working in the way you expected?
  - Have you been concerned at any time that the digital Railcard being presented may not be authentic?
3. Did any other issues arise while you were checking the Railcard?

## NR TICKETS REJECTED AS BEING OUT OF DATE

We recently received a number of separate reports of various NR tickets being rejected by our gates as being out of date, even though the printed expiry date was valid.

Thanks to details of the issuing stations captured by staff at **Oxford Circus**, we were able to identify that the common link between all of the rejected tickets, was that all had been issued from stations that are now operated by South Western Railway.

Subsequent enquiries established that this is a known issue and is due to a particular model of TVM running a changed version of software.

This software contains a bug which incorrectly encodes the date in the magnetic strip on the rear of the ticket. 

These TVMs are in the process of being rolled back to the original software which does not have this issue.

The rollback is due to be completed by **17 October 2017** and as of mid-September, 25% of the 174 TVMs affected have been completed.

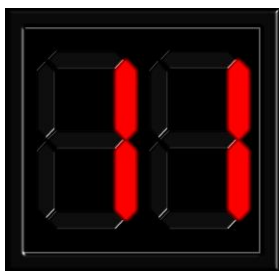
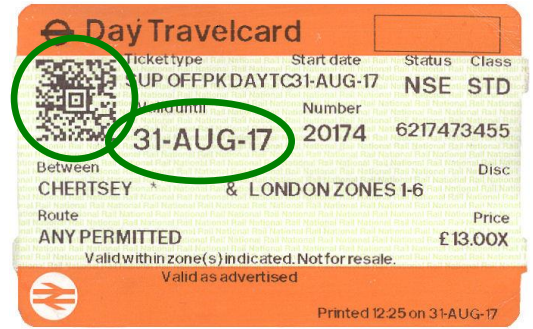

Tickets affected are rejected by LU gates with a reject code "11" displayed on the gate POD. Prior to use on LU, these tickets will actually operate gates on South Western Railway stations, causing some customers to wrongly think that the problem is an LU issue.

If gateline staff receive any complaints from customers about the non-acceptance of these South Western Railway tickets, they should refer the customer to South Western, rather than our own TfL Customer Contact Centre.

## NEW DESIGNS OF ITSO CARDS RELEASED

Updated designs of ITSO "thekey" smartcards have been introduced on the GTR operated **Great Northern**, **Southern** and **Thameslink** railways.

- The card designs shown on the left are all "Adult" retail cards. Other versions include;
- **Child** – same design as for adults, but with the wording "Child" on both the front and reverse of the card.
  - **Staff** – issued to GTR employees and valid for travel on GTR services only
  - **Gateline** – issued to GTR staff who work on gatelines. **NOT VALID FOR TRAVEL.**



As with other ITSO smartcards they are only valid on LU services with a valid Travelcard product and must be used to touch in and out for each journey made.

- As a reminder, ITSO smartcards;
- are only valid on LU when loaded with Travelcard products which also allow travel on LU services.
  - which fail to work the gates must have their reject code checked.
  - can be checked on a POM or TOM, but these devices cannot add products to the card.
  - Must bear a photograph of the holder or be supported by a standard NR Photocard, with a matching name.
- For further information please refer to Section 6.4 of **T&R Book 8**.



← Previous designs of theKey remain in circulation and will continue to work as long as there is a valid product loaded onto the card.

# KEEPING AN EYE ON THE NEIGHBOURS

## WATERLOO GETS BIGGER!

Travel news during August was largely dominated by coverage of the major works at Waterloo (NR).

Conversion of the former Eurostar platforms to provide additional platforms for trains arriving from the south west, coincided with the temporary closure of the existing platforms 1-14, so that these could be extended to increase capacity, by accommodating longer trains. During this period some services were curtailed to reduce pressure on the reduced number of platforms available.

The reopening of the former Eurostar platforms also saw the installation of a new gateline, adding additional gates to this station which already had both the longest single gateline and the largest number of gates.

**SOUTH WEST  
TRAINS**



**South Western  
Railway**



Coinciding with this period of upheaval, we also saw the transfer of the **South West** franchise from the long term incumbent **South West Trains** to the new operator **South Western Railway**, a consortium of First Group (70%) and MTR (30%) from **20 August 2017** until **18 August 2024**.

← As part of this rebranding, South Western Railway has also launched a new design of ITSO card as illustrated on the left.

The previous designs of South West Trains and Stagecoach branded ITSO cards (illustrated below) can still be used and are valid on LU if loaded with a valid Travelcard ↓.



The new franchise saw the launch of a new hi-tech ticketing facility at Waterloo

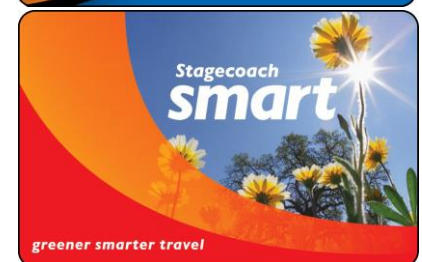

## MiAPPS

There appears to be a little bit of confusion about how the Ticketing Consumable process works, so to help we have put together a few useful bullet points;

- All Ticketing Consumables orders must be submitted via the Mi-Apps Ticketing Consumables E-Form
- These orders are then allocated to the relevant team to process
- Any orders that require processing via SAP E-Procurement (E.G. Multi Safe bags, Secure Suite Log Book) will, once ordered on Mi-Apps, be forwarded to the Cover Group Support in an E-Mail for them to action directly.

**Please note** – It is important that the Cover Group Support then act on this communication and process the order via SAP

The same process as above also applies to orders for Bulk Coin Bags

You can find the list of all items in the Ticketing & Revenue Supplies list via the link below;  
<http://luintranet.tfl/static/documents/coo/Ticketing and Revenue supplies.pdf>







## TICKET IRREGULARITY SURVEY

The results of the May 2017 On-train Ticket Irregularity Survey have been published by the TfL Transport Strategy team. This survey was conducted throughout that month of May by RCIs, following set criteria for each line. Customers were surveyed onboard LU trains covering 7 days of the week, from the first train to the last. In total the survey covered **45,529** customers, of which **2.22%** had a ticket irregularity of one form or another.

Below we have provided a detailed line by line breakdown of the number of customers surveyed in May and the number of offences encountered.

It is worth pointing out that although there is recognised fraudulent travel across the network, almost **98%** of all customers who use our services are in possession of a valid ticket, Oyster card or contactless payment for the journey they make.

Survey Date	On train irregularity	Estimated revenue loss
May 2016	2.54%	1.63%
November 2016	2.64%	1.51%
February 2017	2.28%	1.29%
<b>MAY 2017</b>	<b>2.22%</b>	<b>1.30%</b>
12 month average	2.38%	1.37%

Line	Best	No Checked	Runners	No Ticket	Out of Area (Magnetic)	Adult on Child ticket	PAYG not validated	Out of Area (Oyster)	Other	Total invalid
	Worst									
BAKERLOO		4903	0	35	18	17	15	6	21	112
CENTRAL		5007	2	63	2	7	31	7	25	137
CIRCLE		2752	0	11	6	2	8	5	4	36
DISTRICT		7525	14	52	19	4	64	23	28	204
HAMM & CITY		3439	1	14	8	7	19	11	6	66
JUBILEE		2826	4	22	0	1	5	2	5	39
METROPOLITAN		5541	6	23	16	18	28	21	18	130
NORTHERN		6264	7	53	19	2	37	8	3	129
PICCADILLY		2768	0	26	1	5	13	8	4	57
VICTORIA		4504	36	33	23	13	26	17	0	148
<b>Total (all lines)</b>		<b>45,529</b>	<b>70</b>	<b>332</b>	<b>112</b>	<b>76</b>	<b>246</b>	<b>108</b>	<b>114</b>	<b>1058</b>

### Year on year trends

The table to the right shows the percentages of irregularities from each May survey between 2011 and 2017.

There are a few notable trends and patterns in this data;

- As with February's figures, "No Ticket" offences remain an area of concern recording the highest rates of the past 7 years (currently 31%).
- The trend of a steady reduction in the number of customers with Non-validated PAYG also continues. Down 7% since 2011.
- Although slightly up on last year, Child Impersonation has reduced by half since 2013.
- There has been a 3% drop in Out of Area (Oyster) irregularities, but "Other" offences remain significantly higher than prior to 2014.

Offence (%)	May 2011	May 2012	May 2013	May 2014	May 2015	May 2016	May 2017
No ticket	29	28	29	30	27	28	31
Non validated PAYG	30	26	27	29	27	26	23
Child impersonation	13	13	12	5	9	6	7
Out of area (Oyster)	13	14	13	12	14	12	10
Out of area (Magnetic)	8	10	9	8	9	11	11
Runners	3	4	5	10	3	6	7
Other	4	5	5	6	11	12	11

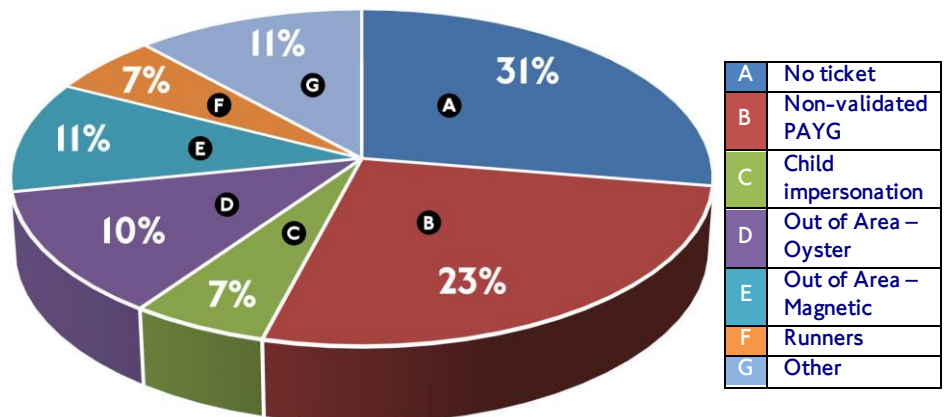

# OYSTER EXPLAINED

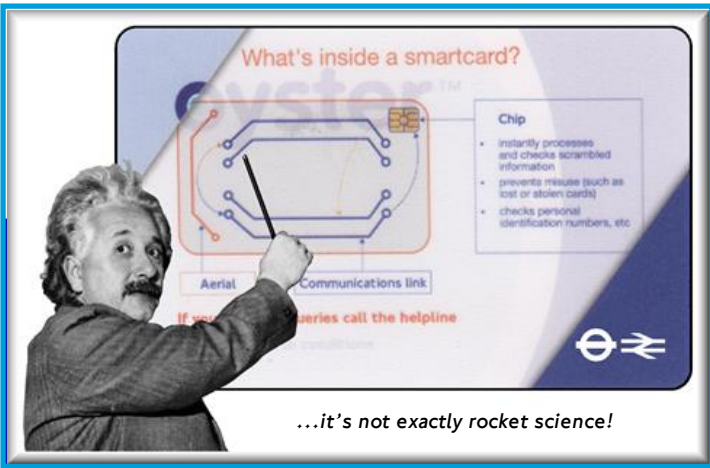

Way way back in TRU27, in the days when Olly was nothing but a petro-chemical in short trousers, we explained how Out of Station Interchanges (OSIs) and Emergency Out of Station Interchanges (EOSIs) worked. We think the time is right to visit this subject again.

## EMERGENCY GATE SETTINGS (revisited)

### OUT of STATION INTERCHANGE (OSI)

This concept has existed since the introduction of the Underground Ticketing System (UTS) in 1987. It now applies to both magnetic tickets and Oyster, and allows a customer to exit the system and resume their journey at an associated gateline within a set time, treating it as a continuous journey from the original entry point, to their final destination.

Interchanges can be programmed individually, taking into account the physical distances between gatelines and the average waiting time and frequency of services.

The number of magnetic ticket OSIs is constrained by the system to approximately 30, examples being Hammersmith (C&H) to Hammersmith (D&P) and Marylebone (LU) to Marylebone (NR).

Magnetic ticket OSIs are characterised by the fact that on exit, all magnetic tickets are returned to customers rather than being captured by the gate.

For Oyster, we are not constrained by the same limited number of OSIs we can set, so there are in fact many more OSIs for Oyster PAYG journeys than for journeys using magnetic tickets.

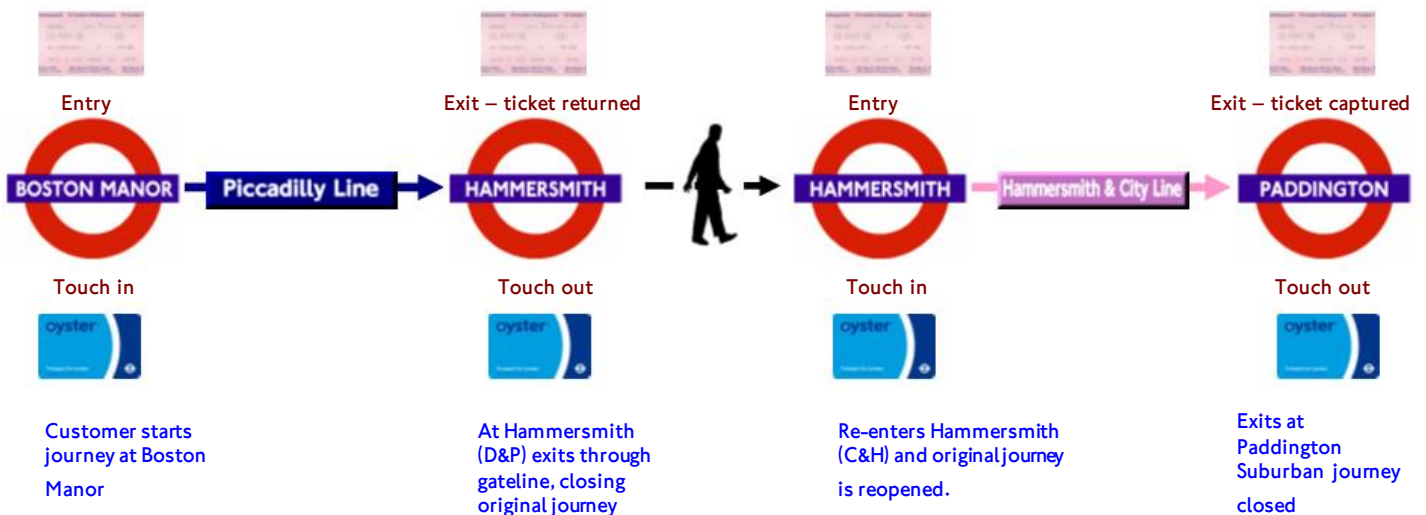

After completion of the first leg of the journey, if an Oyster card is checked on the TOM or POM, the journey would be shown as Boston Manor to Hammersmith. However, if checked again at the end of the journey the TOM or POM would show the journey as Boston Manor to Paddington, omitting any reference to the interchange at Hammersmith. This can sometimes cause confusion, but on more detailed reports produced from central system data, each leg of the journey is shown correctly.

The key message is that for an OSI to function correctly the customer must validate their Oyster card at the beginning and end of each leg of their journey. Otherwise they risk being charged for 2 separate journeys.

### EMERGENCY OUT of STATION INTERCHANGE

In addition to the permanent OSIs set up within base data, when emergencies or service disruption occur, additional Emergency OSIs can be set up to ensure customers are correctly charged if they are forced to break their journey. These are set with a standard interchange time regardless of the locations involved.

## EOSIs (continued)

The facility has also existed since the introduction of UTS and applies to both magnetic tickets and Oyster cards. It can be set from the T&D Operations Centre, or from a POM Room or Station Office SCU via the Emergency Set commands.

This has the effect of setting an emergency bit on the card or ticket which allows the customer to exit the station where it has been set and to recommence their journey at another station within the set time. This behaves in a similar way to the auto-continuation facility.

An example of this in operation would be if a customer is travelling from Holloway Road to Barons Court, when the Piccadilly Line is suspended between Hyde Park Corner and Hammersmith whilst they are enroute.

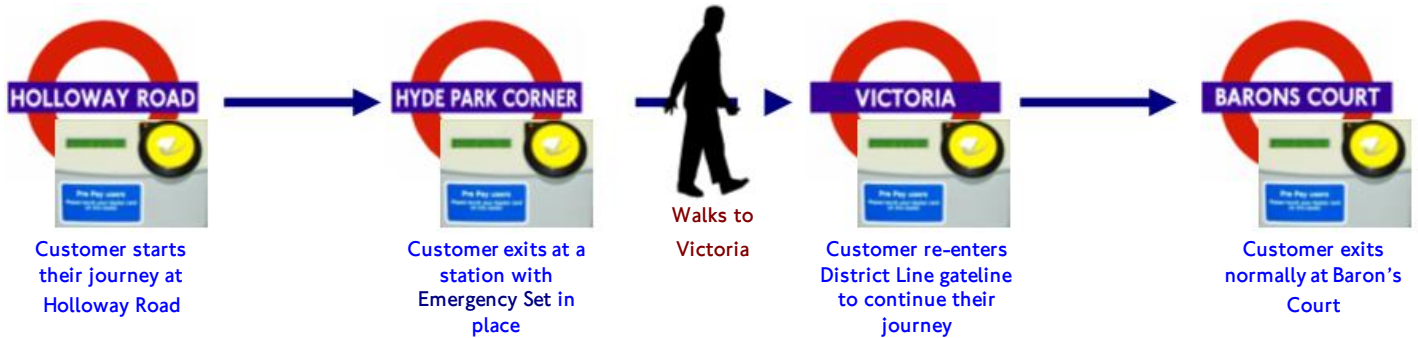

As with the standard OSI, if viewed at the end of the journey, this would be shown on the POM or TOM printout as Holloway Road to Barons Court, without any reference to the validations at Hyde Park Corner or Victoria.

## OSI RE-ENTRY

A number of queries have been raised concerning OSI re-entries. This describes journeys where the customer resumes the second leg of a journey involving an OSI and these normally will not cause a problem. However, in the rare instance of a customer attempting to make another journey within the set time having exited at a station which is an OSI or is set as an EOSI, rather than being recorded as a new journey, this means the customer's previous journey is reopened.

Combining this first and second journey together may result in the customer being undercharged (as illustrated in the example below, but in circumstances where the total journey time from original entry to exit exceeds the maximum journey time, or if the customer returns to their original starting station it may result in two incomplete journeys).

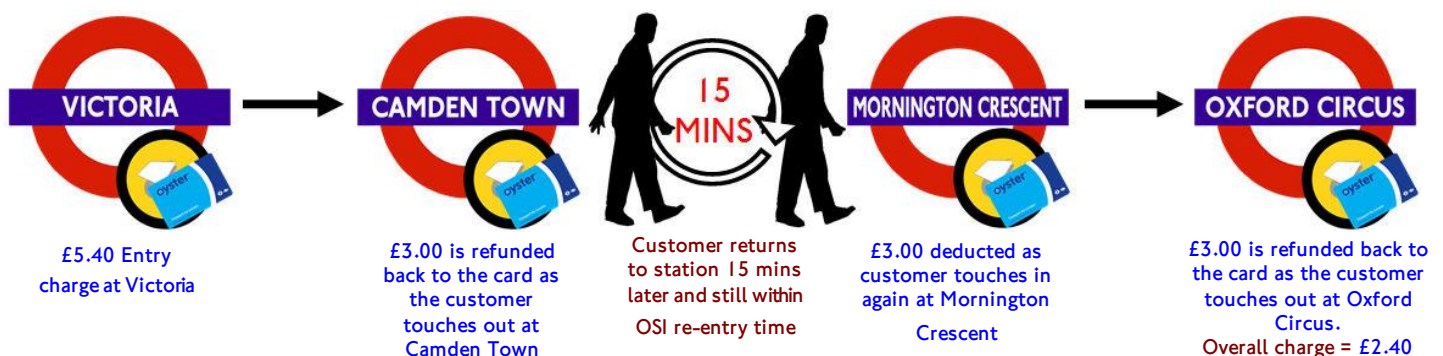

The customer is charged £2.40 instead of £4.80 for the two separate journeys. Had the customer returned to Victoria, they would have been charged for 2 incomplete journeys.

Previous use of the Emergency OSI facility at London Bridge in conjunction with escalator works at Bank / Monument, caused problems with journeys where a customer had made a return journey to / from London Bridge, where there was only a short period between the exit and re-entry. The EOSI feature links the 2 journeys and can result in them being overcharged when returning to their starting point.

The biggest problem for Station staff is that the transaction created by the re-entry cannot be resolved on the TOM or POM and the customer will need to be referred to the Customer Contact Centre for any refund due.

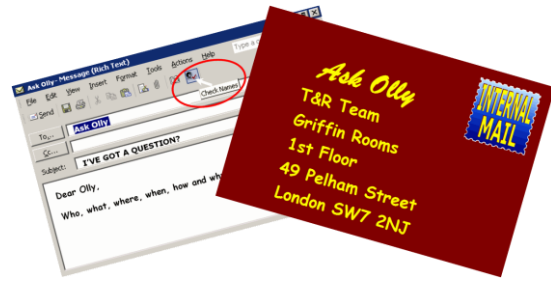

**askolly@tube.tfl.gov.uk**

From: [REDACTED]  
Sent: 26 August 2017 15:01  
To: Ask Ollly  
Subject: Young Visitor Discount

Hi Ollly,

If visitors are staying in London for more than TWO weeks, can we extend the Young Visitor Discount (i.e. to more than the two weeks)?

Many thanks.

[REDACTED]

Hi [REDACTED]

Thanks for your email and query.

The Young Visitor Discount can only be set for a maximum of 14 days. Setting of the discount is monitored and any card on which this discount entitlement is set for a longer period, could potentially result in the card being hotlisted and disabled to prevent potential fraud.

If customers are in London for longer than two weeks, there is no restriction on them asking to have the discount reloaded when it runs out, for the third week of their stay etc.

Hope this clarifies this for you.

Regards

*Olly Oyster*

Hi [REDACTED]

The card that you are describing is almost certainly an ITSO format smartcard issued by South West Trains (now South Western Railway). These can be loaded with Travelcard products in a similar way to Oyster and are valid on LU services if a valid Travelcard is held for the zones being used.

The reject code shown on the gate would be the key to knowing why this particular card did not work. The card can also be checked via the POM screens, which will show what products are loaded and the recent journey history. We have had a couple of issues with ITSO cards being rejected by certain gates due to faults within the RTD (card reader). If the card is rejected it is always worth trying another gate and if it then works, reporting the fault on the gate to the Cubic Helpdesk.

Examples of ITSO format cards are contained within **T&R Book 8**, with some new designs featured on **Page 8** of this edition of TRU.

Regards

*Olly Oyster*

From: [REDACTED]  
Sent: 23 August 2017 22:20  
To: Ask Ollly  
Subject: South West Trains card.

Hi Ollly,

I've recently had a very aggressive customer with a South West Trains Oyster type card that had a Zones 1-6 record card with it, but that the gate said was not supported. I don't remember the code shown.

The supervisor did allow him through but neither of us was sure what to do in this situation.

Many Thanks,

[REDACTED]

From: [REDACTED]  
Sent: 27 August 2017 21:53  
To: Ask Ollly  
Subject: CSID

Hi Ollly,

How do I link this to my new card?

Cheers

[REDACTED]

Hi [REDACTED]

Linkages of TSID cards and CSID PINs are done automatically whenever a CSID PIN is issued or a TSID card is activated via the TSID activation line.

If a Staff Oyster card is replaced by TfL Staff Travel due to a loss or the card failing, then the new Staff Oyster card will need to be relinked to the TSID or CSID PIN.

If this is required a request will need to be submitted by your employing manager (CSM) to either the **TSID** or **CSID** inbox as appropriate, stating the member of staff's new Staff Oyster card number, employee number and TSID card number (where appropriate).

Regards

*Olly Oyster*

From: [REDACTED]  
Sent: 14 September 2017 12:08  
To: Ask Olly  
Subject: Platform Tickets

Hi Olly,

On the east end of the Central line, we are seeing a number of young people buying Platform tickets on the POMs or coming through with Platform tickets issued from another station.

Is there any way that Cubic can stop this kind of ticket from being available?

[REDACTED]

Hi [REDACTED]

The facility to purchase a platform ticket from a POM has existed for many years and hasn't really presented too much of an issue until now.

If you are noticing a pattern of usage at certain stations you need to report this to the Revenue Control team, who may then be able to target regular offenders.

Cubic would not be able to remove the facility without losing it from all devices. However, there are a couple of things that can be done locally to mitigate against the fraudulent purchase of platform tickets;

The facility is not available on POMs if a member of staff is signed onto the associated TOM.

Therefore if you sign onto the TOM in the POM Room and suspend your account customers will not be able to purchase a Platform ticket until you sign-off.

Gates can be set to reject Platform tickets by setting ticket checking and then setting ticket monitoring for the "Platform" category. Details of this appear in T&R Book 8.

Regards

Hi [REDACTED]

Thank you for your email and for highlighting this issue.

Before the start of the current programme to remove acceptance of the old £1 coin from all of our POMs, the T&R team did request the supply of a temporary sticker to highlight to customers which devices did not accept the old £1 coin.

Unfortunately, our requests were turned down, as other parts of the organisation were opposed to "temporary signage".

Not surprisingly when an issue occurs, lots of staff take the initiative in addressing gaps in signage and information and we are aware that many areas have produced their own notices to highlight to their customer the non-acceptance of the old £1 coin. Which is exactly what we predicted would happen.

When we upgraded the AFM to only take new £1 coins we left the MFM at each site to continue to accept the older coins, so that customers with these would still be able to top-up.

From Monday 02 October, Cubic are starting a further round of visits to convert the MFMs. With two weeks to go before the old £1 coins cease to be legal tender, we hope that the volumes still in circulation will now be quite small.

Thanks again for highlighting this issue and apologies that we weren't able to provide what you needed in advance.

Regards

*Olly Oyster*

From: [REDACTED]  
Sent: 29 August 2017 10:24  
To: Ask Olly  
Subject: Old £1 coins no longer taken on AFM's

Hi Olly,

I have had a large amount of customers stating that they can't top up their Oysters on the AFM this morning.

When I checked they were all using the old £1 coins and the coins just fall through to the tray as they now only take the new £1 only.

Obviously we need a better way to tell our customers not to use them, as they do get annoyed and frustrated very quickly.

Some of my colleagues have put their own written notices on the AFMs, however it was pointed out by a manager that it breached the ambience policy.

Therefore I thought I would ask Olly and his friends whether you have any stickers / notices / posters etc. that will not breach the ambience policy and keep our customers happy.

Regards

[REDACTED]

# REVENUE PROJECTS

## UPGRADES RESUME

After a brief pause in the run up to the fares revision on **Sunday 03 September**, the successful completion of the final revision of 2017, as reported on **Page 2**, allowed an early lifting of the fares revision change freeze and for Cubic to resume work on several upgrade programmes.

**Wednesday 06 September**, saw the start of a short Vanguard of a new version of QBM software for all of the devices fitted with the new PED. Five of the 27 devices included within the QBM PED upgrade Vanguard were remotely upgraded with the new software, which included the following main changes.



- New device PC
- New larger screen (same as AFM)
- Hardware modification to receipt printer
- Revised signing on arrangements using Staff Oyster rather than magnetic TSID card
- Green light on new PED card reader will now only illuminate when bankcard payment is available and the payment screen is displayed after selection of a product (as on MFM)
- Software on Windows 7 operating system
- Audible tones when screen pressed (as on AFM)
- Maximum Bankcard limit increased to £750

Unfortunately all didn't go completely to plan, as the first device upgraded; QBM39 at **Embankment**, failed as soon as the new software was downloaded to it on the Wednesday afternoon. It was quickly identified that for this particular upgrade, it would be necessary to 'cold start' each QBM to load a new table for the updated maximum bankcard transaction.

A 'cold start' causes a device to reload all of its tables from the Station Computer (SC) and is used if a particular table is missing or corrupted. All 5 vanguard devices were cold started and successfully upgraded, but this led to a slight change to the planned deployment to the other QBMs with the new PED.

The rest of the 22 Vanguard QBMs and further devices upgraded during the first few nights of the QBM rollout were then updated over a two day period, one week later.

To spread the load of cold starts, arrangements were made for batches of devices to receive the upgrade on the nights of **Wednesday 13 September** and **Thursday 14 September** and further batches during the day on the **Thursday 14** and **Friday 15 September**.

From week commencing **24 September**, any further QBMs updated with the new PED will be immediately upgraded to the latest QBM software, as the new PC will be preloaded with the latest software when it is prepared ready for installation.



## AFM SOFTWARE UPGRADE

Following on from the completion of the rollout of new software to both the MFM and QBM, attention turned to the AFM. With close on 600 devices upgraded with the new PED, this was always going to be the largest job in terms of software deployment.

A ten device Vanguard commenced on **Tuesday 19 September**, involving the first 5 of the following devices, followed by the remaining 5 devices two nights later:

Station	AFM	
LIVERPOOL STREET (C&H)	24	
EMBANKMENT	28	29
CHARING CROSS (Trafalgar Sq)	27	
BLACKFRIARS	29	

Station	AFM	
EUSTON SQUARE	29	
HYDE PARK CORNER	28	29
WESTMINSTER	14	15

After a week of monitoring these devices, the rollout to the remaining AFMs was scheduled to commence on **Tuesday 26 September** initially with 20 devices on the first night, but then increasing to a rate of 50 AFMs per night.

Although there are a large number of devices to be upgraded, this programme should be completed over a period of 12 nights (Sunday through to Friday).

Stations served by Night Tube services will not be included within the upgrades scheduled for the Friday nights, to avoid disruption to customers who may be using an AFM during the night. The final devices are scheduled to be upgraded on the night of **Monday 09 October**.

## HEADS UP ON NEW POLYMER £10

Pre-launch testing of the new Bank of England and Scottish £10 polymer notes at **Liverpool Street** and **Stratford** on **Thursday 24 August** highlighted an issue with acceptance of the new Bank of England £10 note on devices fitted with Bank Note Recycler (BNR) units.

All notes were tested by inserting them in each of the four possible orientations and during this process it was identified that on certain BNR units, notes were consistently rejected in one particular orientation.

***This was with the rear face upper most and the clear window inserted first.*** →

Acceptance in every other orientation was 100%. These results which had not been seen during earlier device testing at the Cubic System testing facility, promoted a review of how best to resolve this issue for the launch of the new note.

A new set of note images were subsequently received from the BNR manufacturers, which addressed the issue with the Bank of England note and a similar issue on one of the designs of Scottish note.

After further testing, a decision was taken to programme an additional technician visit to each of the 98 MFM's with BNR units to update the note set in each device.

Starting on **Monday 11 September** with all devices at **Kings Cross**, an accelerated programme of visits aimed at upgrading all of our BNR units in just over 4 days, with the final devices at **Heathrow T4** and **Heathrow T123**, being upgraded on **Friday 15 September**, the day after the new notes were introduced, but before too many had found their way into general circulation.

The scheduling of these additional visits required some adjustment to the final full week of the AFM CHU update, which removes acceptance of the old £1 coin. This element of the currency changes being completed on **Thursday 21 September**.

Following completion of the work on the AFMs, Cubic will commence a programme of further visits, this time to MFM's with the Bank Note Acceptor (BNA) units, which will see these modified to reject both the old paper £5 note and old design of £1 coin.

The final phase of work will require a further revisit to each of the MFM's with BNR units, to stop them accepting the old pound coin and to re-purpose their £10 note recyclers within the BNR, to utilise the higher capacity unit for polymer £10 notes.

This will then mean that these machines will dispense polymer £10 notes as change or when making refunds, in preference to paper. Prior to the upgrade being done, the devices will dispense paper £10 notes in preference to polymer notes.

This will hopefully see most of our 1,000 plus devices upgraded to no longer accept the old pound coin before they cease to be legal tender on **Saturday 14 October**. As reported on **Page 5**, the last devices should receive the £1 coin upgrade by **Monday 16 October**.

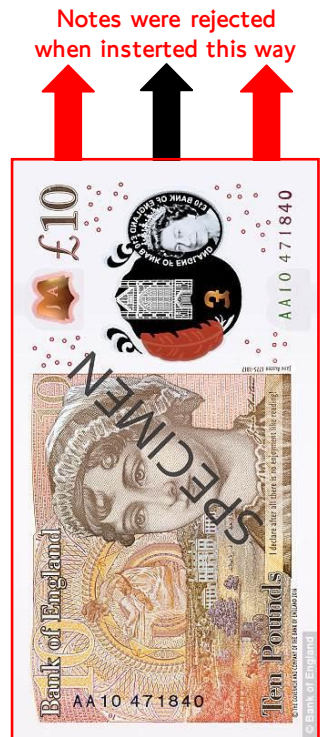

**LAL MXIDE PU** Part 3 – We've mixed up the letters in these station names. Can you work them out?

Ticketing & Revenue  
**T&R**  
Trivia

(a) **NO MOTORS BAN**

(b) **TV DANCER GONE**

(c) **DODGER AWARE**

(d) **OAD FLIP**

(e) **A FRENCH DOILY**

[Answers on page 19.](#)

# REVENUE PROJECTS

## CHD UPGRADES



As reported in [TRU102](#), Scancoin started a programme of upgrades to all of our CHDs to stop the devices from accepting the old design of £1 coin on **Tuesday 29 August**. Most devices are being upgraded remotely during the afternoon, when the units are generally less used.

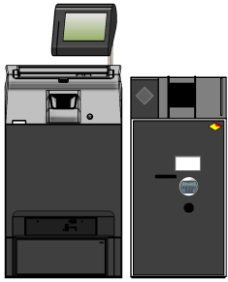

This is the first time we have attempted large scale remote upgrades of the CHDs, which is obviously quicker and more efficient than having to send an engineer to every station. Unfortunately, at present Scancoin are not able to remotely update devices that operate via fixed line IM connection rather than using a wireless modem, so these sites do require a site visit to upgrade the CHD.

We are currently working with Tech & Data to try and resolve why we believe to be an issue with the firewall used by our IM system.

The programme to prevent old £1 acceptance on all CHDs, is scheduled to be completed by **Friday 06 October**, shortly ahead of the completion of works to prevent our MFM's from accepting these coins and a week before the coins cease to be legal tender.

In parallel with the modification to prevent acceptance of the old one pound coin, Scancoin are also undertaking a number of other device upgrades. The main changes being implemented are:

- **Removal of paper £5 note acceptance**
- **Modification of sign-on screen to enforce swiping / insertion of TSID**
- **Changes to improve signing-on when device is offline.**
- **Continuing programme of sorting wheel replacements to prevent counted coins ending up in the wrong hopper.**

The last two of these have already made an improvement in device ability and reduced the number of calls to the CHD Helpline. Previously one of the most common calls related to staff being unable to sign-on and receiving a message saying their user ID was invalid or unavailable.

At stations with MFM's fitted with Bank Note Acceptor (BNA) units, if the CHD has been upgraded to reject the old paper £5 notes, any notes accepted by the MFM will need to be accounted for as valid currency when recording the service on the SAF and banked separately in a counted bag as **VALID** currency. They **should not** be treated as **invalid currency** as we will get the full value from the Bank of England for these notes.



At stations where the MFM is fitted with a Bank Note Recycler, Scancoin will be updating the CHD with a revised note set to allow these CHDs to process the £10 polymer notes issued by the three Scottish note issuing banks when these come into circulation. Please see the article on [Page 3](#), for further details of the release of these notes.

### BANK OF SCOTLAND



### CLYDESDALE BANK



### ROYAL BANK OF SCOTLAND



Join our **email Distribution List** to ensure you get the benefits from;

- the most recent edition of the TRU, on the same day it goes to the printers.
- having your own personal copy.
- access to archived copies.

- Send an email to; [REDACTED] today.





## PED UPDATE

The rollout of the new Chip & PIN unit (PED) resumed on **Sunday 10 September**, with 2 devices being replaced each night (10 per week). The rollout will now continue at this rate until **Friday 10 November**, when all POMs should have been upgraded.

This should mean that work is completed well before the **30 November 2017** when the communications that support the operation of our previous Chip & PIN equipment will no longer be supported and will be switched off. Any devices that haven't been upgraded will not be able to process any bankcard transactions after this date.

Since the start of the QBM rollout an issue has been highlighted affecting a small number of the foreign language screens. When four or five of the languages in the current range are selected, the text runs off the right hand side of the QBM screen, so that the last few characters cannot be seen.

This is evident on the home (Oyster) screen where the message about products that are available appears incomplete in certain languages.

This issue is currently being investigated by Cubic and may be down to an incorrect font being used on certain screens. This will hopefully be rectified in the next base data upgrade to the screens or via a further software release to correct the font size.



In [TRUI02](#), we reported on the completion of AFM works, other than a number of devices which Cubic had been unable to remove to complete the upgrade.

Site visits have now taken place to all of these locations to identify the best method to complete the work, whilst also resolving the problem permanently, so we don't face the same problem next time we need to remove a POM.

Work at the affected stations listed below will be programmed during October, once resources have been confirmed.

Station	AFM	
CANNON STREET	28	29
EAST PUTNEY	29	
ELEPHANT & CASTLE (Northern)	27	28
HOUNSLOW EAST	29	
KINGS CROSS (Tubes)	27	
LONDON BRIDGE (Main)	26	29
SHEPHERDS BUSH (Central)	26	28
STRATFORD (East)	12	
TOTTENHAM COURT ROAD	28	29

## ONE OF OUR BLOCKS IS MISSING!

In [TRUI02](#), we updated you on progress to replace the missing infill blocks from the new PEDs on a number of MFM and AFMs, where these had either not been fitted or had come loose since the PED upgrade had been completed.

Since that article and thanks to feedback from staff at a number of stations, a Cubic team have fitted new blocks which are fractionally smaller than the originals, to a majority of the devices where the block was missing.

There is a chance one or two devices may still have been missed, so if any of your POMs have their infill blocks missing, please send an email to [REDACTED]

It is important to include the device numbers of any POMs which are missing their PED blocks.



# REVENUE PROJECTS

## DATA RE-ROUTED

Back in [TRU88](#) and [TRU100](#) we outlined a “Proof of concept” trial of changing the routing of the data sent to and from devices on our system and the Cubic Central Data System.

At the 4 trial sites listed in the table below, we changed the method of sending data to and from the Station Computer, to use the TfL IM network, rather than using an external router provided by our supplier Level Three.

REGENTS PARK	FARRINGDON	LAMBETH NORTH	LANCASTER GATE
--------------	------------	---------------	----------------

As these sites have successfully operated using our IM network to send and receive data, TfL are now planning to progressively switch all of our stations over onto a TfL IM connection and to remove the need for the current station routers, which are located within the Station Computer Room (SCR).



As the first stage of this migration, Tech & Data (T&D) planned to swap over the first 4 stations to the new connection during week commencing 17 September. The Vanguard stations involved were;

NORTHWOOD	FARRINGDON	PADDINGTON (Suburban)	ROYAL OAK
-----------	------------	-----------------------	-----------

These included Farringdon, which had been included in the original proof of concept trial, as a test for migrating this from the trial connection to a permanent IM connection. Unfortunately issues arose at Northwood, the first site to be attempted on Monday 18 September, which resulted in the temporary suspension of the programme until Wednesday 27 September.

We are currently waiting on the results of the trial installations before confirming the full rollout programme. The initial two phases will focus on the easiest locations, where the current router and an IM connection exist within the SCR. This encompasses around 200 sites.

Following on from this a third phase will cover a further 70 sites where the cable connection between the Station Computer and the IM connection point is relatively short and straight forward.

As with most projects, the difficult sites will be left to nearer the end of the programme.

## LCP3..... UPDATE

Since our last update in [TRU102](#), there has been quite a lot of activity on all three types of gate, to try and bring this long running project to a conclusion.

Testing of new software has been completed for all three gate types and from **Wednesday 20 September**, new software was deployed as a vanguard to all of the E2 gates at **Wood Lane** and to the WAG at **Hounslow East**.



E2 GATE

The revised software has been deployed to resolve a reporting issue that affected around 250 E1 and E2 gates fitted with LCP3 and prevented them from correctly reporting status and performance information to the back office systems used by T&D and Cubic.

A similar vanguard on E1 gates is scheduled to commence on the night of **Thursday 28 September**, involving the E1 gateline at **Oxford Circus** and both of the gatelines at **Southwark**.



E1 GATE

Finally, all of the pneumatic gates involved in the on-going pneumatic gate vanguard at **Old Street**, **Liverpool Street (Central)** and **Tower Hill** were also upgraded with new software between **Wednesday 20** and **Sunday 24 September**.

Prior to these software upgrades taking place, all of the gates involved were fitted with new LCP batteries. It is hoped that the combination of the software and the new batteries will eradicate the '01' error observed on a large number of gates fitted with LCP3.

If all goes well with the current vanguards, Cubic will deploy the new software to all other E1 gates and to E2 gates that have the new LCP. A further go/no go call will then determine whether we expand the current pneumatic gate vanguard into a rollout to all other sites.



P-GATE

## A PEEK AT THE NEW SCU



TOSCU

Work is continuing on the development of a new touchscreen Station Control Unit (SCU), which Cubic plan to deploy to all LU stations next year.

An initial demonstration of the equipment was held recently at Cubic's Salfords development facility.

The new SCU will replace the current life expired monitor and keyboard, with commands being entered directly using designated buttons on the new screens shown on the left.

One of the underlying design features is that there will be fewer button presses to execute a command via the SCU, so each device will have its own button, rather than having to select the device type and then the device number as we do now.

The new design will also overcome to specific issues with the current SCU devices types, which currently do not have buttons for the AFM or QBM. Currently to open or close these devices, you need to select FFM (rather than AFM) or MFM (for a QBM).

Following this initial demonstration, there are a few areas which we have asked Cubic to review and potentially develop alternative options.

The major one of these is around how the new SCU will show whether a gate is operating in entry or exit mode. An initial attempt to show this via symbols [-> etc. was deemed to be not as clear as the current text description.

We will update you further on progress on the development of the new device and the timescales for it to be trialled at a number of stations before the main rollout begins next year.

Ahead of this we will be arranging to survey all stations that have Control Room, Station Office or POM Room SCUs to confirm that the current location of these is correct.

The installation of new cabling to support the deployment of the new SCU, gives us the opportunity to relocate devices which are poorly located and to reinstate some devices that were wrongly removed during the Fit for Future Stations Ticket Office Closure works.

During the following rollout, we will also be looking to remove any redundant SCU equipment that has been left behind and is no longer required.

The location of the Ticket Hall SCU and cabinet will not be changed as part of this work.

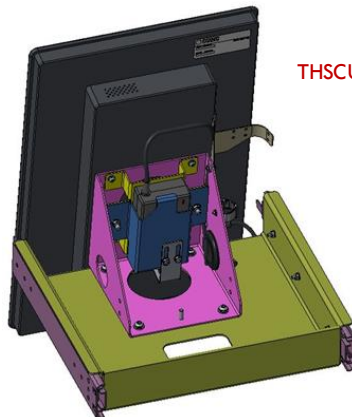

THSCU



## ANSWERS TO T&R TRIVIA

Pt. 1 [See page 1](#)

WHERE'S WOLLY?



Pt. 2 [See page 5](#)

Q2.	B	10 YEARS (AUGUST 2007)
Q3.	A	ASHFIELD HOUSE (2 AFMs were installed at Ashfield House followed two weeks later with the first station trial at Embankment)

Pt. 3 **LAL MXIDE PU** [See page 15](#)



How did you do?

## WHERE HAVE ALL THE LILANGENIES GONE?

In a **Stop Press** item in TRU98 we reported on the successful conclusion of an investigation undertaken with the British Transport Police into the use of large volumes of foreign coins, notably the Swaziland Lilangeni in our POMs at various stations across the network.

On **12 February**, a male suspect was arrested by the BTP at **Golders Green** and was subsequently charged with Fraud, after obtaining Oyster cards and refunds from LU and TOC ticket machines.

At a recent magistrates court appearance the defendant pleaded guilty to the charges and has now been referred to Crown Court for sentencing.

Following the arrest, which also coincided with the start of the rollout of the new Eagle coin validator to our AFMs, we have seen the level of invalid coins accepted by POMs fall dramatically and in a recent four week period, there were only 14 invalid coins recorded across the whole network.

All of these were either £1 or £2 coins recorded as being invalid, although some may actually be genuine coins that were damaged in some way and therefore rejected by the CHD. This is in marked contrast to late 2016, when volumes were running in excess of £2,000 per period.



If coins are continually rejected by the CHD, they should only be declared as Invalid currency if they are non-UK coins or are suspected as being forged. Any coins that appear to be a genuine coin or are damaged and therefore rejected by the CHD should be treated as valid

## ...AND FINALLY!

### EMIRATES AIR LINE – CHANGE TO OPENING TIMES

From Monday 02 October, the Emirates Air Line cable car service which operates across the River Thames, linking the Greenwich Peninsula to the Royal Victoria Dock, will operate to new off-peak opening hours.



The new arrangements are as follows:

Date	Monday to Thursday	Friday	Saturday	Sunday
Opens	0700 hours	0700 hours	0800 hours	0900 hours
Closes	2100 hours	2300 hours	2300 hours	2100 hours

## LOOKING AHEAD TO TRU104

Our next edition, TRU104 is scheduled to be published at the end of October and will be a smaller edition ahead of larger versions in both November and December to cover the January Fares Revision changes.

In TRU104 we plan to cover:

- ❖ Update on the impact of the introduction of the new polymer £10 note
- ❖ A progress report on the various POM upgrades currently underway
- ❖ An update on the Oyster Charity Box scheme
- ❖ Updates on other ticketing projects
- ❖ A further selection of letters to Ask Olly

Plus all the latest T&R news stories and a selection of our other regular features

