

**Figure 35: Area around the Test Vehicle path that must be free from all but clutter defined in the test procedure**

- 6.2.3 The general view ahead and to either side of the test area shall comprise of a wholly plain manmade or natural environment (e.g. further test surface, plain coloured fencing or hoardings, natural vegetation or sky etc.) and must not comprise any highly reflective surfaces or contain any vehicle-like silhouettes that may give rise to abnormal sensor measurements.
- 6.3 Weather Conditions
- 6.3.1 Tests shall be undertaken only in compliance with the following weather conditions:
- Ambient temperatures shall be between 0°C and 45°C
  - No precipitation shall be falling during testing. The surface is permitted to be damp during testing but the quantity of water present on the surface must be less than the amount liable to cause splash or spray during the test.
  - Horizontal visibility at ground level shall be greater than 1km.
  - Wind speeds shall be below 6m/s.
  - Natural ambient illumination must be homogenous in the test area and in excess of 2000 lux with no strong shadows cast across the test area other than those caused by the Test Vehicle, VRU or standardised environmental clutter. Tests shall not be undertaken in such conditions that visual sensors are adversely affected by direct sunlight. However, if it is found that such conditions exist, it shall be recorded in the test report.



## 6.4 Test Targets

- 6.4.1 Pedestrian test targets shall be the EPTa and EPTc and the cyclist test target shall be the EBT. The relevant VRU test targets shall be moved around the test area and delivered to the point of impact with the test vehicle by a low-profile platform.
- 6.4.2 The system will be capable of moving the vulnerable road user at speeds of up to at least 20 km/h, to accelerate at 3 m/s<sup>2</sup> or more, and maintaining constant speed within a tolerance of 0.5 km/h. Lateral deviation from an intended straight path shall be no more than 0.05m.
- 6.4.3 The platform may be self-propelled or moved by a pulley system. However, in either case any visible parts of the combined platform and VRU mounting system shall be of a uniform colour that blends well with the test track beneath it. The default colour is grey.
- 6.4.4 The platform and VRU mounting system shall not influence RADAR return and RADAR absorbing material may be used at the VRU mounting points to ensure compliance with this requirement.
- 6.4.5 The distance between the lower edge of the VRU and the road surface shall be less than 25 mm.

## 7 Vehicle preparation

### 7.1 Aftermarket systems

7.1.1 For aftermarket systems, the system shall be installed on a standard test vehicle of category M<sub>3</sub><sup>21</sup> with the following characteristics:

- a) Overall Length: 9.5 to 11 metres
- b) Number of axles: 2
- c) Axle configuration: 1 front (steered), 1 rear

7.1.2 Where considering the approval of aftermarket systems on vehicles that are different to this specification in terms of length, number of axles or steering configuration, then retesting with the relevant test vehicle shall be required to guarantee satisfactory performance.

### 7.2 OEM systems

7.2.1 For an OEM system, the rating shall apply to the vehicle as a whole and any other models that share the same critical properties. Thus, the test vehicle will be whatever vehicle is supplied by the manufacturer for test, with this recorded in the Test Report.

### 7.3 Dealer fit systems

7.3.1 Dealer fit systems may be tested either as integrated systems for the vehicle or as aftermarket systems fitted to a standard test vehicle. The choice shall be recorded in the Test Report.

<sup>21</sup> As defined by European Type Approval Framework Directive 2007/46/EC



7.4 Blind Spot Safety System

7.4.1 **Installation**

7.4.2 The blind spot safety system to be tested shall be installed on the test vehicle in accordance with the manufacturer’s instructions.

7.4.3 Each blind spot safety system may enable more than one blind spot safety function. Suppliers may market such systems with a variety of optional configurations, including additional functions outside of the scope of this document. The exact configuration of the system tested must be recorded in the Test Report.

7.4.4 It is permitted to install multiple blind spot safety systems on the vehicle. This may arise where multiple separate systems, for example from different suppliers, are installed on the same test vehicle for reasons of increased efficiency. In this case, it must be ensured that no conflict, that has the potential to affect results, occurs between systems in terms of the location and field of view of the sensors, the potential for one sensor to interfere with another or the location of the user interface within the vehicle.

7.5 Settings

7.5.1 Some systems may incorporate driver configurable settings. Where those settings can influence performance, for example the sensitivity of proximity information signal or collision warnings, they shall be set to the middle setting (midpoint), or where this is not possible to the next latest possible setting. Examples are illustrated in Table 20, where a setting that would tend to make an information signal or warning later is one that would reduce the range or sensitivity of the application, whilst earlier would tend to make the application more sensitive or to detect at longer range.

**Table 20: Blind spot safety system setting for testing**

	Setting 1		Setting 2		
Early	Setting 1	Setting 2		Setting 3	Late
	Setting 1	Setting 2	Setting 3	Setting 4	

7.5.2 In this way, a system with only two settings gets adjusted to the least sensitive setting, or latest intervention, a system with 3 possible settings gets adjusted to the midpoint and a system with four settings gets adjusted to the next latest setting from the midpoint.

7.6 Tyres

7.6.1 Perform the testing with road legal tyres of the size, speed and load rating specified by the vehicle manufacturer. Inflate tyres to the pressures recommended by the manufacturer for the least laden normal condition (unladen or lightly laden). Tyre pressures immediately before the test shall be recorded in the Test Report.



7.7 Test Vehicle Mass

7.7.1 The load space on the vehicle shall be empty (unladen condition) except for the driver, test equipment and optionally one test engineer. The fuel tank shall be filled to no less than 90% of the capacity specified by the manufacturer, whilst other fluid levels, such as lubricants etc., are set according to manufacturer recommendations. The mass of the vehicle and its distribution across the axles shall be recorded in the conditions tested.

7.7.2 All test equipment installed in the vehicle should be securely attached to it such that it cannot move under maximum braking forces.



## 8 Test scenarios

8.1 This section describes the methods for testing the performance of blind spot system functions. The overall approach taken is to consider tests relating to two different key collision scenarios: where a bus moves off from rest and where a bus makes a left (nearside) turn. Within each collision scenario, more than one specific test method is required to fully define blind spot system performance in that collision scenario. The method of evaluating the specific results of each individual test and assessment are therefore presented across this section.

### 8.2 **Moving-Off Scenarios**

8.2.1 General Test Scenario Configuration

8.2.1.1 The general test scenario configuration is designed to be representative of collisions where a pedestrian walks in front of a stationary bus in an urban area. The driver moves the bus off from rest, without seeing the VRU in front of the vehicle, resulting in a collision. Representative test vehicle and VRU test target starting positions and intended motions are illustrated in Figure 36, alongside positioning information for the standardised environmental clutter.

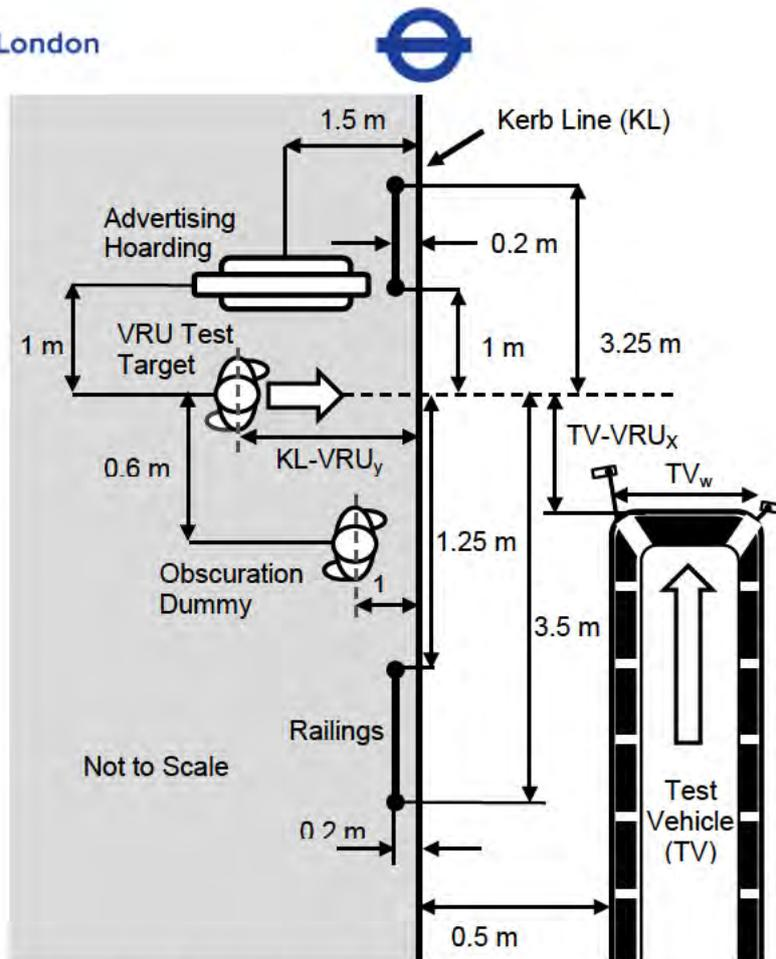

**Figure 36: General test configuration for test vehicle (TV), VRU test target (VRU) and standardised environmental clutter positions at time T0 with intended motions for moving-off test scenarios**

8.2.2 All test scenario configuration dimensions illustrated in Figure 36 are described in greater detail below. Fixed dimensions are enumerated, whilst dimensions that vary with each test scenario are described by their acronym:

- a) Test vehicle width ( $TV_w$ )
- b) Kerb Line (KL) is a line parallel to the global X-axis defining the nominal kerb edge of the road
- c) Lateral distance from nearside edge of TV to KL = 0.5m
- d) Lateral distance from KL to centreline of VRU ( $KL-VRU_y$ )
- e) Longitudinal distance from front of Test Vehicle to centreline of VRU ( $TV-VRU_x$ )
- f) Lateral distance from KL to Obscuration Dummy centreline = 1m
- g) Longitudinal distance from centreline of VRU to centreline of Obscuration Dummy = 0.6m
- h) Lateral distance from KL to centreline of railings = 0.2m



- i) Longitudinal distance from VRU centreline to leading edge of foremost railing = 3.25m
- j) Longitudinal distance from VRU centreline to trailing edge of foremost railing = 1m
- k) Longitudinal distance from VRU centreline to leading edge of rearmost railing = 1.25m
- l) Longitudinal distance from VRU centreline to trailing edge of rearmost railing = 2.5m
- m) Lateral distance from Kerb Line to centreline of Advertising hoarding = 1.5m
- n) Longitudinal distance from VRU centreline to centreline of Advertising Hoarding = 1m



### 8.3 Moving-Off Proximity Information signal (MOPI) Scenario

8.3.1 This test assesses the ability of a system to detect a pedestrian manoeuvring around the front end of a stationary bus and provide an effective VRU proximity information signal. The test vehicle, test targets and standardised environmental clutter shall be set up as specified in Section 8.2.1 with additional test scenario specific parameters as detailed in Table 21.

**Table 21: Definition of test scenario specific parameters for the Moving-Off Proximity Information signal (MOPI) scenario**

Parameter	Test Scenario		
	Adult Near (True Positive)	Child Mid (True Positive)	Adult Far (True Positive)
TV-VRU <sub>y</sub>	1.7 m	1.7 m	1.7 m
TV-VRU <sub>x</sub> <sup>22</sup>	0.3 m	[2.5] m	[4.0] m
VRU Test Target	EPTa	EPTc	EPTa
VRU Speed (V <sub>VRUy</sub> )	3 km/h ± 0.2 km/h	5 km/h ± 0.2 km/h	5 km/h ± 0.2 km/h

8.3.2 For all test scenarios, a constant acceleration of  $1 \text{ m/s}^2 \pm 0.2 \text{ m/s}^2$  ( $A_{VRUy}$ ) shall be applied to the VRU test target in the direction of the negative Y-axis until the steady state VRU speed ( $V_{VRUy}$ ) is met, at which  $A_{VRUy}$  shall drop to a nominal acceleration of  $0 \text{ m/s}^2$  where the steady state speed shall be maintained constant until the VRU has completely passed the front of the test vehicle. The test vehicle ignition shall be switched to the fully on position with test vehicle speeds in both the x-axis and y-axis ( $V_{TVx}$ ,  $V_{TVy}$ ) maintained at 0 km/h through all test scenarios. The motion of the test vehicle and VRU are enumerated below:

- a)  $A_{VRUy} = 1 \text{ m/s}^2 \pm 0.2 \text{ m/s}^2$  until  $V_{VRUy}$  is reached, thereafter nominally  $0 \text{ m/s}^2$ .
- b)  $V_{TVx} = V_{TVy} = 0 \text{ km/h}$ .

8.3.3 The start of each test ( $T_0$ ) shall be taken as the point where the acceleration ( $A_{VRUy}$ ) is first applied to the VRU test target. The completion of each test ( $T_1$ ) shall be taken as the point at which no part of the VRU test target remains in the path of the test vehicle, defined as if the test vehicle moved purely in the x-axis.

8.3.4 The status of the blind spot information and warning signals shall be recorded, along with VRU test target position, from time  $T_0-1$  second to  $T_1$ . The evaluation distance shall be taken as the difference between the VRU test target positions at  $T_0$  and  $T_1$ .

8.3.5 Each specified test scenario shall be undertaken once.

<sup>22</sup> Note that to achieve variation in the longitudinal separation between test vehicle and moving VRU dummy, the path of the VRU shall remain fixed and the start point of the test vehicle shall be moved backward away from the VRU path as required

Transport for London



**MAYOR OF LONDON**





**8.5 Moving-Off collision Warning and motion Inhibit (MOWI) Scenario**

- 8.5.1 This test assesses the ability of a system to detect a pedestrian located in the path of a bus moving off from rest and either intervene to inhibit the motion of the bus or to provide an effective VRU collision warning signal. The test vehicle, test targets and standardised environmental clutter shall be set up as specified in Section 8.2.1 with additional test scenario specific parameters as detailed in Table 22.
- 8.5.2 VRU test targets shall be positioned laterally anywhere between 25% and 75% of the width of the test vehicle (i.e.  $0.25 \cdot TV_w - 0.75 \cdot TV_w$ ), with the exact position determined by the Test Service on a worst-case basis.

**Table 22: Definition of test scenario specific parameters for the Moving-Off collision Warning and motion Inhibit (MOWI) scenario**

Parameter	Test Scenario		
	EPTa Near (Motion Inhibit)	EPTc Near (Motion Inhibit)	EPTa Far (Motion Inhibit or Collision Warning)
TV-VRU <sub>y</sub>	$0.25 \cdot TV_w - 0.75 \cdot TV_w$	$0.25 \cdot TV_w - 0.75 \cdot TV_w$	$0.25 \cdot TV_w - 0.75 \cdot TV_w$
TV-VRU <sub>x</sub> <sup>23</sup>	0.3 m	0.3 m	[4.0] m
VRU Test Target	EPTa	EPTc	EPTc

- 8.5.3 VRU test target speeds in the x-axis and y-axis ( $V_{VRU_x}$ ,  $V_{VRU_y}$ ) shall be maintained at 0 km/h throughout all test scenarios.
- 8.5.4 The test vehicle shall be driven such that it pulls away from rest in the x-axis and towards the VRU test target, before braking to a stop, using the following procedure:
  - a) Select an appropriate forward gear
  - b) Release park brake
  - c) Depress accelerator
  - d) Accelerate to no more than 10 km/h
  - e) Once TTC reduces to  $\leq 0.75$  seconds, decelerate to 0 km/h
- 8.5.5 The start of each test ( $T_0$ ) shall be taken as the point where the acceleration is first applied to the test vehicle. The completion of each test ( $T_1$ ) shall be taken as either the point at which the test vehicle motion inhibit function is activated, the point at which the test vehicle is automatically brought to a halt without driver intervention or the first point at which the TTC becomes 0.75 seconds.

<sup>23</sup> Note that to achieve variation in the longitudinal separation between test vehicle and moving VRU dummy, the path of the VRU shall remain fixed and the start point of the test vehicle shall be moved backward away from the VRU path as required



- 8.5.6 The status of the blind spot information and warning signals and the motion inhibit system shall be recorded, along with the VRU test target and test vehicle positions, from time  $T_0$  to  $T_1 + 3$  seconds. The evaluation distance shall be taken as the difference between the VRU test target positions at  $T_0$  and  $T_1$ .
- 8.5.7 Each specified test scenario shall be undertaken once.
- 8.5.8 Should the motion inhibit function be activated, it shall be deactivated at time no earlier than  $T_1 + 3$  seconds and no later than  $T_1 + 10$  seconds through the motion inhibit over-ride function.
- 8.5.9 The motion inhibit over-ride function shall be applied manually through one of the following conditions:
- A throttle action that requires deliberate additional force similar to kick-down actions or other defined sequence of inputs untypical of normal driving
  - A button that is held down for at least 3 seconds
  - A switch, series of switches or menu-based screen interface, where at least 3 discrete actions are required
- 8.5.10 A collision warning signal shall be issued whilst the motion inhibit over-ride function is applied.
- 8.5.11 With the motion inhibit over-ride function applied, the test vehicle shall be driven away from the test target to a finish point no further than 10 m away where no further hazards are present.
- 8.5.12 The motion inhibit over-ride function shall deactivate before reaching the finish point described in 8.5.11.



## 8.7 Nearside Turn Scenarios

### 8.7.1 General Test Scenario Configuration

8.7.2 The general test scenario configuration is designed to be representative of collisions with VRUs during nearside turn manoeuvres in an urban area. Two categories of test scenario are assessed: the first where a bicyclist cycles alongside the nearside of a bus about to perform a nearside turn manoeuvre and the second where a pedestrian crosses the entrance of a road on the nearside of a bus about to perform a nearside turn manoeuvre into the road. Representative test vehicle and VRU test target starting positions and intended motions are illustrated in Figure 37, alongside positioning information for the standardised environmental clutter.

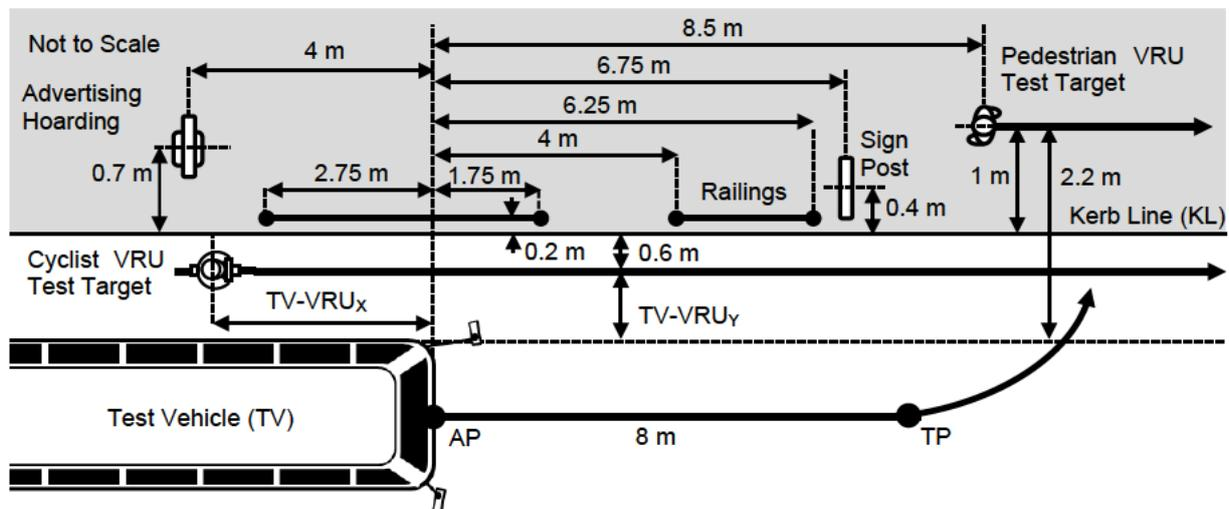

**Figure 37: General test configuration for test vehicle (TV), VRU test target (VRU) and standardised environmental clutter positions at time T0 with intended motions for nearside turn test scenarios**

8.7.3 All test scenario configuration dimensions illustrated in Figure 37 are described in greater detail below. Fixed dimensions are enumerated, whilst dimensions that vary with each test scenario are described by their acronym:

- Test vehicle length ( $TV_L$ )
- Kerb Line (KL) is a line parallel to the global X-axis defining the nominal kerb edge of the road, prior to the simulated junction.
- Acceleration Point (AP) is the X-position of the foremost point of the test vehicle at the moment the test vehicle begins to accelerate
- Turn Point (TP) is the X-position of the foremost point of the test vehicle at the moment that the test vehicle commences steering
- Longitudinal distance from AP to centreline of cyclist VRU ( $TV-VRU_x$ )
- Lateral distance from nearside of Test Vehicle to centreline of cyclist VRU ( $TV-VRU_y$ )
- Lateral distance from KL to centreline of cyclist VRU = 0.6 m



- h) Longitudinal distance from AP to centreline of pedestrian VRU = 8.5 m
- i) Lateral distance from nearside of Test Vehicle to centreline of cyclist VRU = 2.0 m
- j) Lateral distance from KL to centreline of cyclist VRU = 1.0 m
- k) Longitudinal distance from AP to TP = 8.0 m
- l) Lateral distance from KL to centreline of railings = 0.2 m
- m) Longitudinal distance from AP to leading edge of foremost railing = 6.25 m
- n) Longitudinal distance from AP to trailing edge of foremost railing = 4.0 m
- o) Longitudinal distance from AP to leading edge of rearmost railing = 1.75 m
- p) Longitudinal distance from AP to trailing edge of rearmost railing = 2.75 m
- q) Lateral distance from KL to centreline of Advertising Hoarding = 0.7m
- r) Longitudinal distance from AP to centreline of Advertising Hoarding = 4.0 m
- s) Lateral distance from KL to centreline of signpost = 0.4 m
- t) Longitudinal distance from AP to centreline of signpost = 6.75 m



## 8.9 Nearside Turn Proximity Information signal (NTPI) Scenario

8.9.1 This test assesses the ability of a system to detect a cyclist manoeuvring along the nearside of a stationary bus and provide an effective VRU proximity information signal. The test vehicle, test target and standardised environmental clutter shall be set up as specified in Section 8.7.1 with additional test scenario specific parameters detailed in Figure 38 and Table 23.

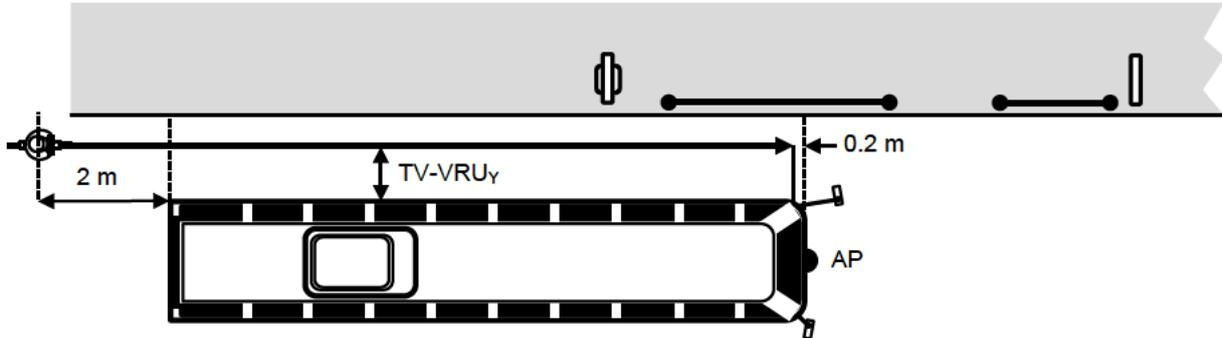

**Figure 38: Test target positions at time  $T_0$  and  $T_1$  for Nearside Turn Proximity Information signal (NTPI) scenario whilst test vehicle is stationary**

**Table 23: Definition of test scenario specific parameters for the Nearside Turn Proximity Information signal (NTPI) scenario**

Parameter	Test Scenario	
	Cyclist Near (True Positive)	Cyclist Far (True Positive)
$TV_x$	AP	AP
$TV-VRU_y$	0.6 m	[1.5] m
$TV-VRU_x$	$TV_L + 2$ m	$TV_L + 2$ m
<b>VRU Test Target</b>	EBT	EBT

8.9.2 For all test scenarios, the VRU test target shall be accelerated in the direction of the positive X-axis to a steady state speed of  $10 \text{ km/h} \pm 0.2 \text{ km/h}$  within a distance of 2 m. The VRU test target speed shall be maintained as constant until decelerated to rest at a rate of  $2 \text{ m/s}^2 \pm 0.5 \text{ m/s}^2$  such that the test target comes to rest at a position 0.2 m rearward of the AP (in the negative X-axis). The test vehicle ignition shall be switched to the fully on position with test vehicle speeds in both the x-axis and y-axis ( $V_{TV_x}$ ,  $V_{TV_y}$ ) maintained at 0 km/h throughout all test scenarios.

8.9.3 The start of each test ( $T_0$ ) shall be taken as the point where the acceleration is first applied to the VRU test target. The completion of each test ( $T_1$ ) shall be taken as the point at which the VRU test target comes to rest.

8.9.4 The status of the blind spot information and warning signals shall be recorded, along with VRU test target position, from time  $T_0 - 1$  second to  $T_1$ . The evaluation distance shall be taken as between  $VRU_x = TV_L - 1$  m and the VRU test target position at  $T_1$ .

8.9.5 Each specified test scenario shall be undertaken once



8.10 **Nearside Turn Low relative Cyclist speed (NTLC) Scenario**

8.10.1 This test assesses the ability of a system to detect a cyclist manoeuvring at a low relative speed along the nearside of a bus performing a nearside turn and provide effective VRU proximity information and collision warning signals. The test vehicle, test target and standardised environmental clutter shall be set up as specified in Section 8.7.1 with additional test scenario specific parameters as detailed in Figure 39 and Table 24.

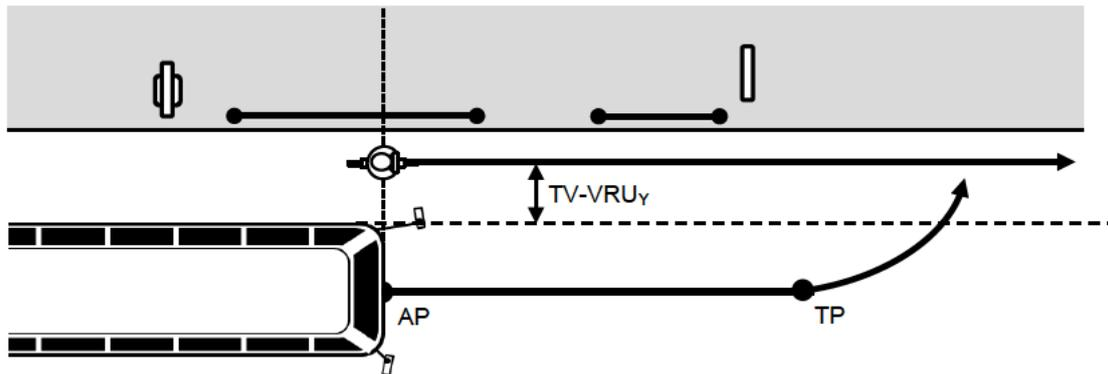

Figure 39: Test vehicle and test target position at time  $T_0$  for Nearside Turn Low relative Cyclist speed (NTLC) scenario

Table 24: Definition of test scenario specific parameters for the Nearside Turn Low relative Cyclist speed (NTLC) scenario

Parameter	Test Scenario	
	Cyclist Near (True Positive)	Cyclist Far (True Positive)
$TV_x$ at $T_0$	AP	AP
$TV-VRU_y$ at $T_0$	0.6 m	[1.5] m
$TV-VRU_x$ at $T_0$	0 m	0 m
VRU Test Target	EBT	EBT
TV Angle of Turn ( $\alpha$ ) at $T_2$	$27^\circ$	$35^\circ$
$VRU_x$ at $T_2$	AP + 10 m	AP + 11.25 m

8.10.2 For all test scenarios, the test vehicle shall be accelerated in the X-axis direction to a steady state speed of 10 km/h  $\pm$  1 km/h within a distance of 8 m. The test vehicle speed shall be maintained as constant until the completion of the test ( $T_1$ ). At the turn point (TP), steering shall be applied to the test vehicle such that the foremost point of the test vehicle centreline follows the arc of a circle with a radius (R) of 10 m.

8.10.3 The VRU test target shall commence acceleration at the moment in time when the test vehicle X-axis position is 0.2m greater than that of the AP. The VRU test target shall be accelerated in the direction of the positive X-axis to a nominal steady state speed of 6.5 km/h within a distance of 2 m.



- 8.10.4 The moment in time at which the VRU test target path would conflict with the test vehicle path ( $T_2$ ) shall be defined as the impact point. On reaching the impact point, the test vehicle shall have travelled the length of a 10 m radius arc with an angle of turn of  $\alpha$  (where  $\alpha$  is defined as the central angle of a circle measured in degrees, see Figure 40), whilst the VRU test target shall have reached a position  $VRU_x$ .

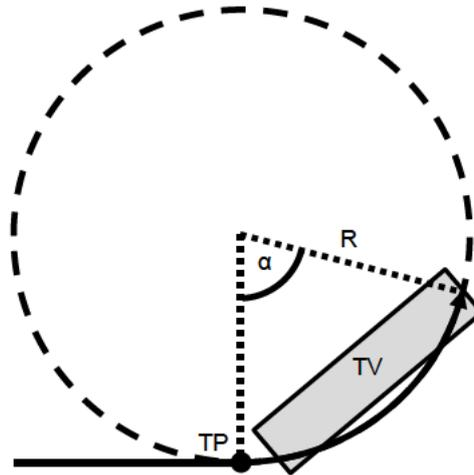

**Figure 40: Illustration of central angle ( $\alpha$ ) of arc of a circle of radius ( $R$ ) relating to the steering applied to the test vehicle ( $TV$ ) from the turn point ( $TP$ )**

- 8.10.5 The speed of the VRU test target may be varied in response to the actual speed and path achieved by the test vehicle to ensure compliance with the above impact point criteria. This moment approximates the moment of impact, but it should be noted that the exact point of impact on the vehicle and the exact time of impact will vary slightly depending on the steering geometry of the test vehicle.
- 8.10.6 The start of each test ( $T_0$ ) shall be taken as the point where the acceleration is first applied to the test vehicle. The completion of each test ( $T_1$ ) shall be taken as the moment in time 1 second before the impact point (i.e.  $T_1 = T_2 - 1$  second).
- 8.10.7 To avoid unnecessary damage to the VRU test target, the test vehicle and test target shall both be decelerated to a halt between  $T_1$  and  $T_2$ .
- 8.10.8 The status of the blind spot information and warning signals shall be recorded, along with the VRU test target and test vehicle positions, from time  $T_0$  to  $T_1 + 3$  seconds. The proximity test evaluation distance shall be taken as the difference between the VRU test target positions at  $T_0$  and  $TP$ , whilst the collision test evaluation distance shall be taken as the difference between positions at  $TP$  and  $T_1$ .
- 8.10.9 Each specified test scenario shall be undertaken once.



## 8.12 Nearside Turn High relative Cyclist speed (NTHC) Scenario

8.12.1 This test assesses the ability of a system to detect a cyclist manoeuvring at a high relative speed along the nearside of a bus performing a nearside turn and provide effective VRU proximity information and collision warning signals. The test vehicle, test target and standardised environmental clutter shall be set up as specified in Section 8.7.1 with additional test scenario specific parameters as detailed in Figure 41 and Table 25.

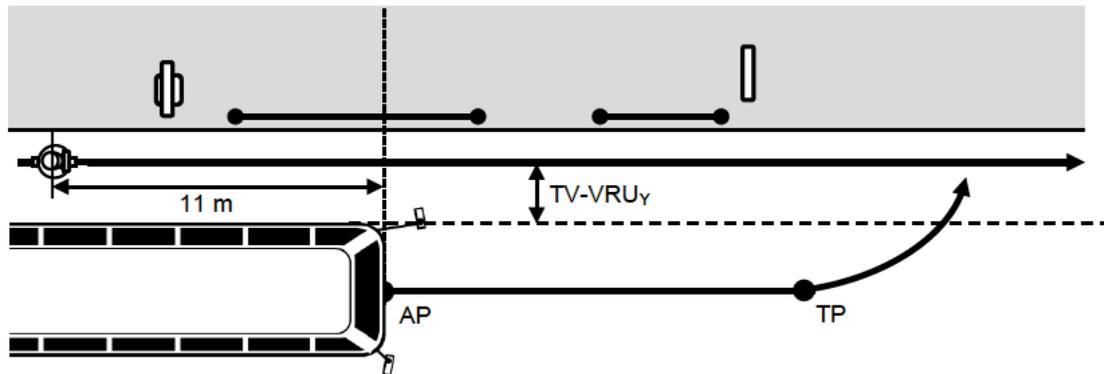

**Figure 41: Test vehicle and test target position at time  $T_0$  for Nearside Turn High relative Cyclist speed (NTHC) scenario**

- 8.12.2 For all test scenarios, the test vehicle shall be accelerated from its start position to a steady state speed of 4 km/h and maintained as constant until the acceleration point (AP). At the AP, the test vehicle shall be accelerated in the X-axis direction to a steady state speed of 14 km/h  $\pm$  1 km/h within a distance of 8 m. The test vehicle speed shall be maintained as constant until the completion of the test ( $T_1$ ). At the turn point (TP), steering shall be applied to the test vehicle such that the foremost point of the test vehicle centreline follows the arc of a circle with a radius (R) of 10 m.
- 8.12.3 Prior to the test vehicle reaching the AP, the VRU test target shall be accelerated from its start position to a nominal steady state speed of 18 km/h. As the test vehicle reaches the AP, the VRU shall be a distance of 11 m  $\pm$  0.5 m rearward of the AP in the negative X-axis.
- 8.12.4 Start positions and initial accelerations for the test vehicle and VRU test target shall be at the discretion of the Test Service to ensure compliance with these positioning requirements.



**Table 25: Definition of test scenario specific parameters for the Nearside Turn High relative Cyclist speed (NTHC) scenario**

Parameter	Test Scenario	
	Cyclist Near (True Positive)	Cyclist Far (True Positive)
TV <sub>x</sub> at T <sub>0</sub>	AP	AP m
TV-VRU <sub>y</sub> at T <sub>0</sub>	0.6 m	[1.5] m
TV-VRU <sub>x</sub> at T <sub>0</sub>	AP – 11 m	AP – 11 m
VRU Test Target	EBT	EBT
TV Angle of Turn (α) at T <sub>2</sub>	27°	35°
VRU <sub>x</sub> at T <sub>2</sub>	AP + 10 m	AP + 11.25 m

- 8.12.5 The moment in time at which the VRU test target path would conflict with the test vehicle path (T<sub>2</sub>) shall be defined as the impact point. On reaching the impact point, the test vehicle shall have travelled the length of a 10 m radius arc with an angle of turn of α (Figure 40), whilst the VRU test target shall have reached a position VRU<sub>x</sub>.
- 8.12.6 The speed of the VRU test target may be varied in response to the actual speed and path achieved by the test vehicle to ensure compliance with the above impact point criteria. This moment approximates the moment of impact, but it should be noted that the exact point of impact on the vehicle and the exact time of impact will vary slightly depending on the steering geometry of the test vehicle.
- 8.12.7 The start of each test (T<sub>0</sub>) shall be taken as the point where the acceleration is first applied to the test vehicle. The completion of each test (T<sub>1</sub>) shall be taken as the moment in time 1 second before the impact point (i.e. T<sub>1</sub>=T<sub>2</sub>-1 second).
- 8.12.8 To avoid unnecessary damage to the VRU test target, the test vehicle and test target shall both be decelerated to a halt between T<sub>1</sub> and T<sub>2</sub>.
- 8.12.9 The status of the blind spot information and warning signals shall be recorded, along with the VRU test target and test vehicle positions, from time T<sub>0</sub> to T<sub>1</sub> + 3 seconds. The proximity test evaluation distance shall be taken as the difference between the VRU test target positions at T<sub>0</sub> and TP, whilst the collision test evaluation distance shall be taken as the difference between positions at TP and T<sub>1</sub>.
- 8.12.10 Each specified test scenario shall be undertaken once.



## 8.14 Nearside Turn Crossing Pedestrian (NTCP) Scenario

8.14.1 This test assesses the ability of a system to detect a pedestrian crossing an entrance to a road whilst the bus performs a nearside turn into the road and provide effective VRU proximity information and collision warning signals. The test vehicle, test target and standardised environmental clutter shall be set up as specified in Section 8.7.1 with additional test scenario specific parameters as detailed in Figure 42.

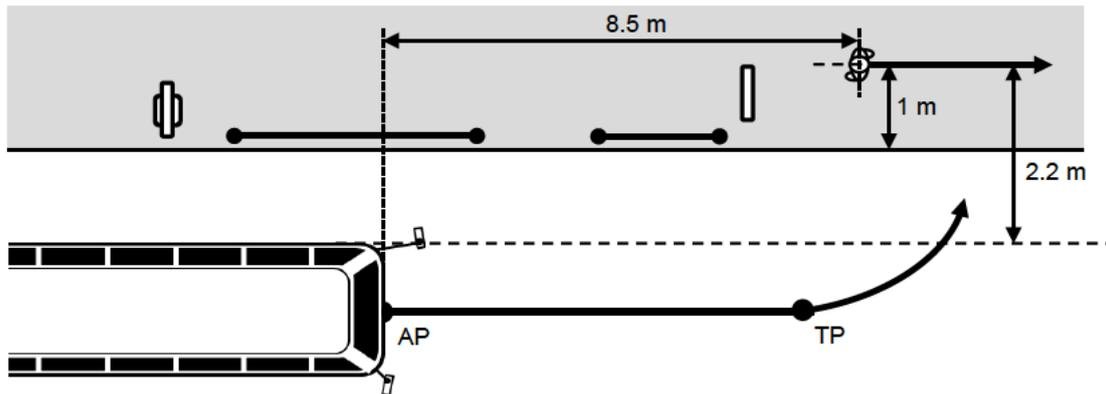

**Figure 42: Test vehicle and test target position at time  $T_0$  for Nearside Turn Crossing Pedestrian (NTCP) scenario**

- 8.14.2 The test vehicle shall be accelerated in the X-axis direction to a steady state speed of  $10 \text{ km/h} \pm 1 \text{ km/h}$  within a distance of 8 m. Test vehicle speed shall be maintained as constant until the completion of the test ( $T_1$ ). At the turn point (TP), steering shall be applied to the test vehicle such that the foremost point of the test vehicle centreline follows the arc of a circle with a radius (R) of 10 m.
- 8.14.3 The VRU test target shall be accelerated in the direction of the positive X-axis to a nominal steady state speed of 5 km/h within a distance of 2 m. The VRU test target shall commence acceleration at the moment in time such that, when the test vehicle has travelled the length of a 10 m radius arc with an angle of turn of  $35^\circ$  (Figure 40), the VRU test target shall have reached a position  $\text{VRU}_x = \text{AP} + 12.1 \text{ m}$ . The moment in time that this point occurs shall be defined as the impact point ( $T_2$ ).
- 8.14.4 The speed of the VRU test target may be varied in response to the actual speed and path achieved by the test vehicle to ensure compliance with the above impact point criteria. This moment approximates the moment of impact, but it should be noted that the exact point of impact on the vehicle and the exact time of impact will vary slightly depending on the steering geometry of the test vehicle.
- 8.14.5 The start of each test ( $T_0$ ) shall be taken as the point where the acceleration is first applied to the test vehicle. The completion of each test ( $T_1$ ) shall be taken as the moment in time 1 second before the impact point (i.e.  $T_1 = T_2 - 1 \text{ second}$ ).



- 8.14.6 To avoid unnecessary damage to the VRU test target, the test vehicle and test target shall both be decelerated to a halt between  $T_1$  and  $T_2$ .
- 8.14.7 The status of the blind spot information and warning signals shall be recorded, along with the VRU test target and test vehicle positions, from time  $T_0$  to  $T_1 + 3$  seconds. The proximity test evaluation distance shall be taken as the difference between the VRU test target positions at  $T_0$  and TP, whilst the collision test evaluation distance shall be taken as the difference between positions at TP and  $T_1$ .
- 8.14.8 This test scenario shall be undertaken once.



8.16 **Nearside Turn No test Target (NTNT) Scenario**

8.16.1 This test assesses the false positive rate of a system in high levels of environmental clutter for both the VRU proximity information and collision warning signals. This may be used to evaluate the effectiveness of the system in differentiating between the at-risk VRUs and the environment. The test vehicle and standardised environmental clutter shall be set up as specified in Section 8.7.1, with additional test scenario specific parameters as detailed in Figure 43.

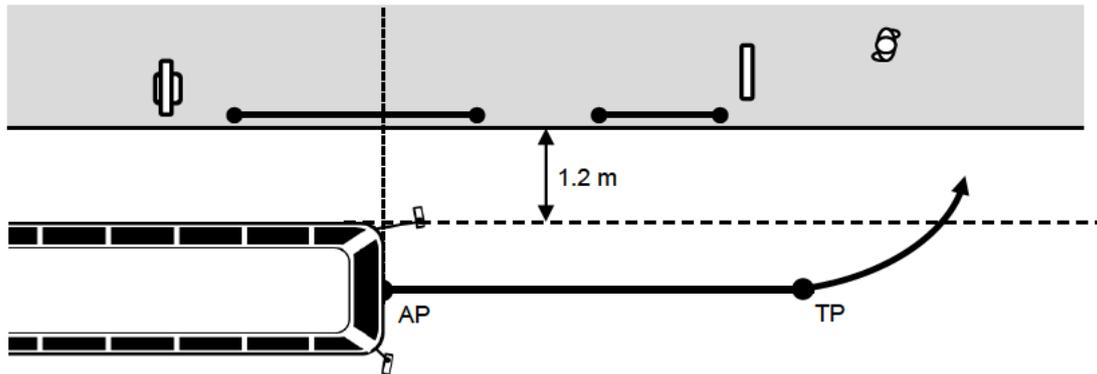

**Figure 43: Test vehicle and test target position at time  $T_0$  for Nearside Turn No test Target (NTNT) scenario**

- 8.16.2 The test vehicle shall be accelerated in the X-axis direction to a steady state speed of  $10 \text{ km/h} \pm 1 \text{ km/h}$  within a distance of 8 m. Test vehicle speed shall be maintained as constant until the completion of the test ( $T_1$ ). At the turn point (TP), steering shall be applied to the test vehicle such that the foremost point of the test vehicle centreline follows the arc of a circle with a radius (R) of 10 m.
- 8.16.3 The start of each test ( $T_0$ ) shall be taken as the point where the acceleration is first applied to the test vehicle. The completion of each test ( $T_1$ ) shall be taken as the moment in time that the test vehicle has traversed the arc of the circle for an angle of turn ( $\alpha$ ) of  $75^\circ$ .
- 8.16.4 The status of the blind spot information and warning signals shall be recorded, along with the VRU test target and test vehicle position, from time  $T_0 - 1$  second to  $T_1$ . The evaluation distance shall be taken as the difference between the VRU test target positions at  $T_0$  and  $T_1$ .
- 8.16.5 This test scenario shall be undertaken once.



## 9 Assessment of results

### 9.1 Moving-Off Proximity Information signal (MOPI) Scenario

#### 9.1.1 Test Scenario Performance Evaluation

9.1.1.1 The evaluation of the blind spot system performance during the Moving-Off Proximity Information signal (MOPI) test scenarios shall be assessed according to Table 26.

**Table 26: Evaluation of test performance for the Moving-Off Proximity Information signal (MOPI) test scenarios**

Test Scenario	Points Available	Result Criteria	Result Metric	Score
<b>All Scenarios (False Positive)</b>	-2 to 0	Proximity information signal status before $T_0$ in any test condition	Inactive [0] Active [-2]	
<b>Adult Near (True Positive)</b>	0 to 1	Proportion of evaluation distance for which proximity information signal was active	100% Active [1] 100% Inactive [0]	
<b>Child Mid (True Positive)</b>	0 to 1		100% Active [1] 100% Inactive [0]	
<b>Adult Far (False Positive)</b>	-1 to 0		100% Inactive [0] 100% Active [-1]	
<b>All Scenarios (False Positive)</b>	-2 to 0	Collision warning status in any test scenario	Inactive [0] Active [-2]	
<b>Max. Points</b>	<b>2</b>	<b>Total Score</b>		
<b>Total Score/Max. Points</b>				



9.1.2 **HMI Performance Evaluation**

9.1.3 The evaluation of the performance of the blind spot system HMI across all Moving-Off Proximity Information signal (MOPI) test scenarios shall be assessed according to Table 27.

**Table 27: Evaluation of human-machine interface (HMI) performance for the Moving-Off Proximity Information signal (MOPI) test scenarios**

HMI Criteria	Points Available	Result Criteria	Score
Proximity information signal transmitted over the visual mode only	0 to 3	Visual [3] Tonal or Haptic or Speech [0]	
Visual proximity information signal is located within a horizontal field of view angle of between $\pm 30^\circ$ , without causing an obstruction to direct or indirect vision	0 to 1	In zone [1] Out of zone [0]	
Visual proximity information signal is amber in colour	0 to 1	Amber [1] Other colour [0]	
Visual proximity information signal ceases automatically within [1] second of the VRU moving out of vehicle path	0 to 1	Ceases within [1] sec [1] Does not cease/ceases in $\geq 1s$ [0]	
<b>Max. Points</b>	<b>6</b>	<b>Total Score</b>	
<b>Total Score/Max. Points</b>			



**9.2 Moving-Off collision Warning and motion Inhibit (MOWI) Scenario**

9.2.1 Test Scenario Performance Evaluation

9.2.1.1 The evaluation of the blind spot system performance during the Moving-Off collision Warning and motion Inhibit (MOWI) test scenarios shall be assessed in accordance with Table 28.

**Table 28: Evaluation of test performance for the Moving-Off collision Warning and motion Inhibit (MOWI) test scenarios**

Test Scenario	Points Available	Result Criteria	Result Metric	Score
Adult Near (Motion Inhibit)	0 to 1	The vehicle remains stationary despite the driver actions	Stationary [1] Motion [0]	
Child Near (Motion Inhibit)	0 to 1		Stationary [1] Motion [0]	
Child Far (Motion Inhibit or Collision Warning)	0 to 1	The vehicle remains stationary despite the driver actions, or is automatically brought to a halt without driver intervention before the point of collision	Stationary [1] Halted: No Driver Intervention [1] Halted: With Driver Intervention [0]	
	0 to 1	Proportion of evaluation distance for which collision warning was active	100% Active [1] 100% Inactive [0]	
<b>Max. Points</b>	<b>3</b>	<b>Total Score</b>		
<b>Total Score/Max. Points</b>				

9.2.2 HMI Performance Evaluation

9.2.2.1 The evaluation of the performance of the blind spot system HMI across all Moving-Off collision Warning and motion Inhibit (MOWI) test scenarios shall be assessed in accordance with Table 29.



**Table 29: Evaluation of human-machine interface (HMI) performance for the Moving-Off collision Warning and motion Inhibit (MOWI) test scenarios**

HMI Criteria	Points Available	Result criteria	Score
Collision warning signal is transmitted over at least two modes	0 to 1	Multi-mode [1] Single mode [0]	
Collision warning signal is transmitted over at least one of audible/haptic modes	0 to 1	Includes Audible/Haptic Mode [1] No Audible/Haptic Modes [0]	
Collision warning signal uses a different mode to the proximity information signal or is distinctly different in presentation	0 to 1	Different [1] Similar [0]	
Visual collision warning signal is located within a horizontal field of view angle of between $\pm 30^\circ$ , without causing an obstruction to direct or indirect vision	0 to 1	In zone [1] Out of zone [0]	
Visual collision warning signal is red in colour	0 to 1	Red [1] Other colour [0]	
Visual collision warning signal displayed on windscreen via a head-up display that does not obstruct driver vision	0 to 1	HUD [1] No HUD [0]	
Audible collision warning signal does not use speech coding	0 to 1	Tonal [1] Speech Coding [0]	
Tonal collision warnings are distinct from other sounds used within the vehicle	0 to 1	Distinct [1] Similar [0]	
Tonal collision warnings have a signal to ambient noise ratio of greater than 1.3 between relevant loudness spectra	0 to 1	>1.3 [1] $\leq 1.3$ [0]	
Collision warning signal automatically ceases in less than [1] second after $T_1$	0 to 1	Ceases within 1 sec [1] Does not cease/ceases in $\geq 1s$ [0]	
<b>Max. Points</b>	<b>10</b>	<b>Total Score</b>	
		<b>Total Score/Max. Points</b>	



### 9.3 Nearside Turn Proximity Information signal (NTPI) Scenario

#### 9.3.1 Test Scenario Performance Evaluation

9.3.1.1 The evaluation of the performance of the blind spot system during the Nearside Turn Proximity Information signal (NTPI) test scenarios shall be assessed in accordance with Table 30.

**Table 30: Evaluation of test performance for the Nearside Turn Proximity Information signal (NTPI) test scenarios**

Test Scenario	Points Available	Result Criteria	Result Metric	Score
All Scenarios (False Positive)	-2 to 0	Proximity information signal status before T <sub>0</sub> in any test scenario	Inactive [0] Active [-2]	
Cyclist Near (True Positive)	0 to 1	Proportion of evaluation distance for which proximity information signal was active	100% Active [1] 100% Inactive [0]	
Cyclist Far (True Positive)	0 to 1	Proportion of evaluation distance for which proximity information signal was active	100% Active [1] 100% Inactive [0]	
All Scenarios (False Positive)	-2 to 0	Collision warning status in any test scenario	Inactive [0] Active [-2]	
<b>Max. Points</b>	<b>2</b>	<b>Total Score</b>		
				<b>Total Score/Max. Points</b>

### 9.4 HMI Performance Evaluation

9.4.1.1 The evaluation of the performance of the blind spot system HMI across all Nearside Turn Proximity Information signal (NTPI) test scenarios shall be assessed according to Table 31.

**Table 31: Evaluation of human-machine interface (HMI) performance for the Nearside Turn Proximity Information signal (NTPI) test scenarios**

HMI Criteria	Points Available	Result Criteria	Score
Proximity information signal transmitted over the visual mode only	0 to 3	Visual [3] Tonal or Haptic or Speech [0]	
Visual proximity information signal is located within a horizontal field of view angle of 30°-60° towards the nearside of the vehicle, without causing an obstruction to direct or indirect vision	0 to 1	In zone [1] Out of zone [0]	
Visual proximity information signal is amber in colour	0 to 1	Amber [1] Other colour [0]	
<b>Max. Points</b>	<b>5</b>	<b>Total Score</b>	



## 9.5 Nearside Turn Low relative Cyclist speed (NTLC) Scenario

### 9.5.1 Test Scenario Performance Evaluation

9.5.1.1 The evaluation of the performance of the blind spot system during the Nearside Turn Low relative Cyclist speed (NTLC) test scenarios shall be assessed in accordance with Table 32.

**Table 32: Evaluation of test performance for the Nearside Turn Low relative Cyclist speed (NTLC) test scenarios**

Test Scenario	Points Available	Result Criteria	Result Metric	Score
<b>Cyclist Near (Proximity Information Signal)</b>	0 to 1	Proportion of proximity test evaluation distance for which proximity information signal was active	100% Active [1] 100% Inactive [0]	
<b>Cyclist Near (Collision Warning)</b>	0 to 2	Proportion of collision test evaluation distance for which collision warning was active	100% Active [2] 100% Inactive [0]	
<b>Cyclist Near (Premature Collision Warning)</b>	-2 to 0	Collision warning status before TP in any test scenario	Inactive [0] Active [-2]	
<b>Cyclist Far (Proximity Information Signal)</b>	0 to 1	Proportion of proximity test evaluation distance for which proximity information signal was active	100% Active [1] 100% Inactive [0]	
<b>Cyclist Far (Collision Warning)</b>	0 to 2	Proportion of collision test evaluation distance for which collision warning was active	100% Active [2] 100% Inactive [0]	
<b>Cyclist Far (Premature Collision Warning)</b>	-2 to 0	Collision warning status before TP in any test scenario	Inactive [0] Active [-2]	
<b>Max. Points</b>	<b>6</b>	<b>Total Score</b>		
<b>Total Score/Max. Points</b>				



9.5.2 HMI Performance Evaluation

9.5.2.1 The evaluation of the performance of the blind spot system HMI across all Nearside Turn Low relative Cyclist speed (NTLC) test scenarios shall be assessed according to Table 33.

**Table 33: Evaluation of human-machine interface (HMI) performance for the Nearside Turn Low relative Cyclist speed (NTLC) test scenarios**

HMI Criteria	Points Available	Result Criteria	Score
Proximity information signal transmitted over the visual mode only	0 to 3	Visual [3] Tonal or Haptic or Speech [0]	
Visual proximity information signal is located within a horizontal field of view angle of 30°-60° towards the nearside of the vehicle, without causing an obstruction to direct or indirect vision	0 to 1	In zone [1] Out of zone [0]	
Visual proximity information signal is amber in colour	0 to 1	Amber [1] Other colour [0]	
Visual proximity information signal ceases automatically on activation of the collision warning signal	0 to 1	Ceases on Activation [1] Does not cease on Activation [0]	
Collision warning signal is transmitted over at least two modes	0 to 1	Multi-mode [1] Single mode [0]	
Collision warning signal is transmitted over at least one of audible/haptic modes	0 to 1	Includes Audible/Haptic Mode [1] No Audible/Haptic Modes [0]	
Collision warning signal uses a different mode to the proximity information signal or is distinctly different in presentation	0 to 1	Different [1] Similar [0]	
Visual collision warning signal is located within a horizontal field of view	0 to 1	In zone [1] Out of zone [0]	



towards the nearside of the vehicle, without causing an obstruction to direct or indirect vision			
Visual collision warning signal is red in colour	0 to 1	Red [1] Other colour [0]	
Audible collision warning signal does not use speech coding	0 to 1	Tonal [1] Speech Coding [0]	
Tonal collision warnings are distinct from other sounds used within the vehicle	0 to 1	Distinct [1] Similar [0]	
Tonal collision warnings have a signal to ambient noise ratio of greater than 1.3 between relevant loudness spectra	0 to 1	>1.3 [1] ≤1.3 [0]	
Collision warning signal automatically ceases in less than [2] seconds after $T_1$	0 to 1	Ceases within 2 secs [1] Does not cease/ceases in ≥2s [0]	
<b>Max. Points</b>	<b>15</b>	<b>Total Score</b>	
		<b>Total Score/Max. Points</b>	





**9.6 Nearside Turn High relative Cyclist speed (NTHC) Scenario**

**9.6.1 Test Scenario Performance Evaluation**

9.6.1.1 The evaluation of the performance of the blind spot system during the Nearside Turn High relative Cyclist speed (NTHC) test scenarios shall be assessed in accordance with Table 34.

**Table 34: Evaluation of test performance for the Nearside Turn High relative Cyclist speed (NTHC) test scenarios**

Test Scenario	Points Available	Result Criteria	Result Metric	Score
<b>Cyclist Near (Proximity Information Signal)</b>	0 to 1	Proportion of proximity test evaluation distance for which proximity information signal was active	100% Active [1] 100% Inactive [0]	
<b>Cyclist Near (Collision Warning)</b>	0 to 2	Proportion of collision test evaluation distance for which collision warning was active	100% Active [2] 100% Inactive [0]	
<b>Cyclist Near (Premature Collision Warning)</b>	-2 to 0	Collision warning status before TP in any test scenario	Inactive [0] Active [-2]	
<b>Cyclist Far (Proximity Information Signal)</b>	0 to 1	Proportion of proximity test evaluation distance for which proximity information signal was active	100% Active [1] 100% Inactive [0]	
<b>Cyclist Far (Collision Warning)</b>	0 to 2	Proportion of collision test evaluation distance for which collision warning was active	100% Active [2] 100% Inactive [0]	
<b>Cyclist Far (Premature Collision Warning)</b>	-2 to 0	Collision warning status before TP in any test scenario	Inactive [0] Active [-2]	
<b>Max. Points</b>	<b>6</b>	<b>Total Score</b>		
<b>Total Score/Max. Points</b>				



9.6.2 HMI Performance Evaluation

9.6.2.1 The evaluation of the performance of the blind spot system HMI across all Nearside Turn Low relative Cyclist speed (NTLC) test scenarios shall be assessed according to Table 35.

**Table 35: Evaluation of human-machine interface (HMI) performance for the Nearside Turn Low relative Cyclist speed (NTLC) test scenarios**

HMI Criteria	Points Available	Result Criteria	Score
Proximity information signal transmitted over the visual mode only	0 to 3	Visual [3] Tonal or Haptic or Speech [0]	
Visual proximity information signal is located within a horizontal field of view angle of 30°-60° towards the nearside of the vehicle, without causing an obstruction to direct or indirect vision	0 to 1	In zone [1] Out of zone [0]	
Visual proximity information signal is amber in colour	0 to 1	Amber [1] Other colour [0]	
Visual proximity information signal ceases automatically on activation of the collision warning signal	0 to 1	Ceases on Activation [1] Does not cease on Activation [0]	
Collision warning signal is transmitted over at least two modes	0 to 1	Multi-mode [1] Single mode [0]	
Collision warning signal is transmitted over at least one of audible/haptic modes	0 to 1	Includes Audible/Haptic Mode [1] No Audible/Haptic Modes [0]	
Collision warning signal uses a different mode to the proximity information signal or is distinctly different in presentation	0 to 1	Different [1] Similar [0]	
Visual collision warning signal is located within a horizontal field of view angle of 30°-60° towards the nearside of the vehicle, without causing an obstruction to direct or indirect vision	0 to 1	In zone [1] Out of zone [0]	





<b>an obstruction to direct or indirect vision</b>			
<b>Visual collision warning signal is red in colour</b>	0 to 1	Red [1] Other colour [0]	
<b>Audible collision warning signal does not use speech coding</b>	0 to 1	Tonal [1] Speech Coding [0]	
<b>Tonal collision warnings are distinct from other sounds used within the vehicle</b>	0 to 1	Distinct [1] Similar [0]	
<b>Tonal collision warnings have a signal to ambient noise ratio of greater than 1.3 between relevant loudness spectra</b>	0 to 1	>1.3 [1] ≤1.3 [0]	
<b>Collision warning signal automatically ceases in less than [2] seconds after T<sub>1</sub></b>	0 to 1	Ceases within 2 secs [1] Does not cease/ceases in ≥2s [0]	
<b>Max. Points</b>	<b>15</b>	<b>Total Score</b>	
			<b>Total Score/Max. Points</b>



**9.7 Nearside Turn Crossing Pedestrian (NTCP) Scenario**

**9.7.1 Test Scenario Performance Evaluation**

9.7.1.1 The evaluation of the performance of the blind spot system during the Nearside Turn Crossing Pedestrian (NTCP) test scenario shall be assessed according to Table 36.

**Table 36: Evaluation of test performance for the Nearside Turn Crossing Pedestrian (NTCP) test scenario**

Test Scenario	Points Available	Result Criteria	Result Metric	Score
<b>Pedestrian (Proximity Information Signal)</b>	0 to 1	Proportion of proximity test evaluation distance for which proximity information signal was active	100% Active [1] 100% Inactive [0]	
<b>Pedestrian (Collision Warning)</b>	0 to 2	Proportion of collision test evaluation distance for which collision warning was active	100% Active [2] 100% Inactive [0]	
<b>Pedestrian (Premature Collision Warning)</b>	-2 to 0	Collision warning status before TP in any test scenario	Inactive [0] Active [-2]	
<b>Max. Points</b>	<b>3</b>	<b>Total Score</b>		
<b>Total Score/Max. Points</b>				



9.7.2 HMI Performance Evaluation

9.7.2.1 The evaluation of the performance of the blind spot system HMI across all Nearside Turn Low relative Cyclist speed (NTLC) test scenarios shall be assessed according to Table 37.

**Table 37: Evaluation of human-machine interface (HMI) performance for the Nearside Turn Crossing Pedestrian (NTCP) test scenario**

HMI Criteria	Points Available	Result Criteria	Score
Proximity information signal transmitted over the visual mode only	0 to 3	Visual [3] Tonal or Haptic or Speech [0]	
Visual proximity information signal is located within a horizontal field of view angle of 30°-60° towards the nearside of the vehicle, without causing an obstruction to direct or indirect vision	0 to 1	In zone [1] Out of zone [0]	
Visual proximity information signal is amber in colour	0 to 1	Amber [1] Other colour [0]	
Visual proximity information signal ceases automatically on activation of the collision warning signal	0 to 1	Ceases on Activation [1] Does not cease on Activation [0]	
Collision warning signal is transmitted over at least two modes	0 to 1	Multi-mode [1] Single mode [0]	
Collision warning signal is transmitted over at least one of audible/haptic modes	0 to 1	Includes Audible/Haptic Mode [1] No Audible/Haptic Modes [0]	
Collision warning signal uses a different mode to the proximity information signal or is distinctly different in presentation	0 to 1	Different [1] Similar [0]	
Visual collision warning signal is located within a horizontal field of view angle of 30°-60°	0 to 1	In zone [1] Out of zone [0]	



towards the nearside of the vehicle, without causing an obstruction to direct or indirect vision			
Visual collision warning signal is red in colour	0 to 1	Red [1] Other colour [0]	
Audible collision warning signal does not use speech coding	0 to 1	Tonal [1] Speech Coding [0]	
Tonal collision warnings are distinct from other sounds used within the vehicle	0 to 1	Distinct [1] Similar [0]	
Tonal collision warnings have a signal to ambient noise ratio of greater than 1.3 between relevant loudness spectra	0 to 1	>1.3 [1] ≤1.3 [0]	
Collision warning signal automatically ceases in less than [2] seconds after $T_1$	0 to 1	Ceases within 2 secs [1] Does not cease/ceases in ≥2s [0]	
<b>Max. Points</b>	<b>15</b>	<b>Total Score</b>	
		<b>Total Score/Max. Points</b>	





**9.8 Nearside Turn No test Target (NTNT) Scenario**

**9.8.1 Test Scenario Performance Evaluation**

9.8.1.1 The evaluation of the performance of the blind spot system during the Nearside Turn No test Target (NTNT) test scenario shall be assessed in accordance with Table 38. No assessment of the HMI performance shall be performed for the Nearside Turn No test Target (NTNT) test scenario.

**Table 38: Evaluation of test performance for the Nearside Turn No test Target (NTNT) test scenario**

Test Scenario	Points Available	Result Criteria	Result Metric	Score
<b>Proximity Information Signal (False Positive)</b>	-1 to 0	Proximity information signal status in any test scenario	Inactive [0] Active [-1]	
<b>Collision Warning (False Positive)</b>	-2 to 0	Collision warning status in any test scenario	Inactive [0] Active [-2]	
<b>Max. Points</b>	<b>0 (min -3)</b>	<b>Total Score</b>		
<b>Total Score/Max. Points</b>				



9.9 **General HMI Evaluation**

9.9.1 Formal independent tests need not be undertaken in respect of the additional HMI requirements specified in Table 39. Assessment may be based on documentary evidence provided by the system supplier and demonstration of functionality. The general HMI parameters that attract additional credit are identified in Table 39.

**Table 39: Requirements for warning systems**

HMI Criteria	Points Available	Result criteria	Score
The device automatically switches off above a speed of 30 km/h	0 to 1	Switches Off [1] Does Not Switch Off [0]	
The operational status of the device is communicated to the driver	0 to 1	Status Communicated [1] Status Not Communicated [0]	
Visual displays use colour combinations recommended by ISO 15008:2009	0 to 1	Recommended [1] Not recommended [0]	
Visual displays shall have a brightness of $\geq 6000 \text{ cd/m}^2$ in daylight conditions	0 to 1	$\geq 6000 \text{ cd/m}^2$ [1] $< 6000 \text{ cd/m}^2$ [0]	
Visual displays have a (manually or automatically) adjustable brightness to compensate for ambient conditions	0 to 1	Adjustable [1] Fixed [0]	
Visual displays are of sufficient size with minimum dimensions of 12 mm x 12 mm on driver side and 20 mm x 20 mm on passenger side of vehicle	0 to 1	Sufficient Size [1] Insufficient Size [0]	
<b>Max. Points</b>	<b>6</b>	<b>Total Score</b>	
<b>Total Score/Max. Points</b>			

9.9.2 Motion inhibit systems shall be over-rideable by the driver to continue making progress in the event of a false positive



**9.10 Quality, Durability and Installation Requirements**

9.10.1 Additional score will be awarded if the system or vehicle supplier can demonstrate documentary evidence of compliance with the requirements in Table 40.

**Table 40: Requirements for Quality, Durability and Installation**

Criteria	Points Available	Result criteria	Score
<b>Complies with EN50498 for Electro-Magnetic Compatibility</b>	0 to 1	Compliant [1] Not Compliant [0]	
<b>Complies with UNECE Regulation 10.04 for immunity to radio frequency interference (RFI)</b>	0 to 1	Compliant [1] Not Compliant [0]	
<b>Complies with ISO 11452-9 or ISO 11451-3</b>	0 to 1	Compliant [1] Not Compliant [0]	
<b>Complies with the Mechanical Test aspects of ISO 16001</b>	0 to 1	Compliant [1] Not Compliant [0]	
<b>Complies with the Mechanical Test aspects of ISO 15998</b>	0 to 1	Compliant [1] Not Compliant [0]	
<b>Max. Points</b>	<b>5</b>	<b>Total Score</b>	
<b>Total Score/Max. Points</b>			

**9.11 Overall Rating**

9.11.1 Each of the individual assessments defined across the previous sections will provide a normalised performance score between 0 and 1. Due to the characteristics of the London collision landscape, however, some test scenarios are deemed to be more important than others for preventing bus-to-VRU collisions. These individual scores are, therefore, weighted by importance then summed together to produce an overall Blind Spot information signal, Warning and intervention (BSW) performance score between 0% and 100%, as shown in Table 41.



**Table 41: Weightings for overall Blind Spot information signal, Warning and intervention (BSW) performance rating score**

Scenario	Evaluation Method	Evaluation Score (E)	Scenario Weighting	Collision Population Weighting	Scenario Weighting	Evaluation Method Weighting	Overall Weighting (W)	Weighted Score (W*E)
<b>Moving-Off Proximity Information signal (MOPI)</b>	Performance		90%	57%	45%	75%	0.173	
	HMI					25%		0.058
<b>Moving-Off collision Warning and motion Inhibit (MOWI)</b>	Performance		90%	57%	55%	95%	0.268	
	HMI					5%		0.014
<b>Nearside Turn Proximity Information signal (NTPI)</b>	Performance		90%	15%	20%	75%	0.020	
	HMI					25%		0.007
<b>Nearside Turn Low relative Cyclist speed (NTLC)</b>	Performance		90%	15%	30%	75%	0.030	
	HMI					25%		0.010
<b>Nearside Turn High relative Cyclist speed (NTHC)</b>	Performance		90%	15%	30%	75%	0.030	
	HMI					25%		0.010
<b>Nearside Turn Crossing Pedestrian (NTCP)</b>	Performance		90%	28%	100%	75%	0.189	
	HMI					25%		0.063
<b>Nearside Turn No test Target (NTNT)</b>	Performance		90%	15%	20%	75%	0.020	
	HMI					25%		0.007
<b>Additional HMI Requirements</b>						5%	0.050	
<b>Quality, Durability &amp; Installation</b>						5%	0.050	
<b>Overall BSW Performance Rating Score (%)</b>								



## 10 Test Report

- 10.1 The Test Service shall provide a comprehensive Test Report that will be made available to TfL. The test report shall consist of three distinct sections:
- a) Performance data
  - b) Confirmation of protocol compliance
  - c) Reference information
- 10.2 The minimum performance data required is the completion of each table of results listed in this document.
- 10.3 In order to confirm protocol compliance, the Test Service shall:
- a) include in the report processed data (e.g. graphs, tables etc.) that show that each test was compliant with its associated variables and tolerances
  - b) provide data on environmental validity criteria, including temperature, weather and lighting measurements, demonstrating compliance with respective limit values.
- 10.4 The reference information required includes as a minimum:
- a) Vehicle Make
  - b) Vehicle Model
  - c) Vehicle Model Variant
  - d) BSW Hardware version (e.g. sensor types, ECU references)
  - e) BSW Software version



# Attachment 25: Blind Spot Warning

## Guidance Notes

---

### 1 Introduction

Separate requirements are intended to ensure that drivers have a good field of view from a bus in respect to vulnerable road users (VRUs) in close proximity to the bus. The aim of the Blind Spot information signal, Warning and intervention (BSW) safety measure is to recognise that good vision alone will not guarantee that drivers will successfully avoid all collisions with VRUs in close proximity to buses performing low speed manoeuvres. Information signals, warnings and interventions based on the detection of vulnerable road users through electronic sensing systems can, therefore, still have a significant potential benefit in these circumstances.

This document sets out the guidance notes related to the testing and assessment of the safety performance of BSW systems. These guidance notes are aimed at bus operators and manufacturers as a practical guide for implementation of the Bus Safety Standard.

These notes are for guidance only, and are not legally binding. In all circumstances, guidance provided by the manufacturer of a bus or system shall take precedence, and these guidance notes are only for use in the absence of other information. These are not intended to be exhaustive, but to point the operators toward practical advice and questions to raise with manufacturers/suppliers.

### 2 Selection of buses/systems

Any bus that meets the TfL Bus Vehicle Specification.

The blind spot information warning and intervention (BSW) requirements may be assessed against a new build bus with functions integrated in the factory by the bus OEM, or against a vehicle fitted with a system supplied by an organisation other than a bus OEM either for dealer fit or as an aftermarket fitment.

#### 2.1 Compliance and warranty

A bus operator should seek evidence from the system supplier and/or bus manufacturer that a dealer fit or aftermarket fitted device does not create any warranty problems for the bus OEM. Operators should also be aware that a regulation governing the technical standards of systems with some of the functionality described in the assessment is in development and will be applied to HGVs. It is possible that this may be extended to buses, but any regulatory requirements will only apply to new buses first registered from the relevant future date. It will not render devices fitted before that time illegal, even if they do not comply with the new requirements.



## 2.2 Interpreting the requirements and selecting the most effective way to fulfil them

In order to recognise a potentially dangerous situation during low speed manoeuvres and successfully avoid a collision, then the following elements are required:

- **Available to be seen:** The hazard (pedestrian, cyclist, other vehicle etc.) needs to be available to be seen by the driver sufficiently ahead of time to allow avoiding action to be taken. That is, the hazard needs to be in view at least around 2 seconds before collision.
- **Alert and attentive:** The driver needs to be attentive to the road and traffic environment and alert to the possible need to react.
- **Looking in the right direction:** In complex driving situations, the driving task can demand attention in multiple different directions; the driver needs to be looking in the right direction at the right time to see the hazard. In dynamic moving environments this is not guaranteed even if the driver is alert and attentive.
- **Recognition:** Once the hazard is seen, then the driver must recognise the hazard and the risk that it poses.
- **Reaction:** Once the risk is recognised, the driver must react quickly and correctly to the risk. In some circumstances this may be steering around the hazard, in many it will be braking the vehicle to a stop and in others it might simply be to remain stationary instead of moving off from rest.

Thus, the ability to avoid a collision in the low speed manoeuvring circumstances envisaged for BSW systems is also strongly related to the vision performance of the bus and so the two safety measures should be considered together so that they are complementary and work in synergy.

BSW systems can supplement the vision requirements in circumstances where the hazard is still unavailable to be seen by the driver. However, the main benefit is likely to be in drawing the drivers attention to the presence of the hazard when, either for legitimate reasons of driver workload or for reasons of distraction or fatigue, the driver is not looking in the direction of the hazard at the exact time needed to avoid collision. In these circumstances the BSW can draw the driver attention to the right spot at the right time where the hazard will be visible in direct or indirect vision such that it maximises the chance of prompt recognition and correct reactions.

In order to achieve this, the way that the systems interact with the driver to inform them, warn them or intervene on their behalf is considered critical to the likely success of the system. This aspect of system design is known as the human-machine interface, or HMI. Measures are in place to encourage good HMI in the test and assessment protocol and are based on established industry standards (e.g. ISO standards). They are typically related to the criticality of the driving situation (is a collision likely in the next couple of seconds, in a longer period or not necessarily likely at all) and the urgency of the warning. However, HMI has inevitable subjective elements and can be difficult to measure objectively so there will still be room for substantial variation in the systems available on the market. The guidance below provides both the rationale for the protocol requirements and information to help operators choose systems that they believe will work well with their vehicles, in the operating environments the vehicles will be used in and by their drivers.



## 2.3 Proximity information signals

Proximity information signals are systems that will inform the driver any time a vulnerable road user is in close proximity to the vehicle. In London traffic these will be issued very frequently. In the vast majority of these situations, the situation will not be critical i.e. a collision will not be imminent in the next couple of seconds and the driver may well already be well aware of the presence of the hazard. Thus, reaction to non-critical situations should be discouraged and the warning should not be urgent or intrusive. In these circumstances an urgent, intrusive warning such as a loud tonal sound, a buzzer etc. can be annoying to the driver. They may subconsciously tune the warning out such that they ignore it when it is really needed or they may even find ways of disabling the system. Thus, examples of amber visual warnings may be much more acceptable to the driver in the many cases where the situation is not critical and/or they were already aware, while still providing useful information about the presence of hazards, when they are hidden or the driver has not seen them.

## 2.4 Collision warnings

Collision warnings should be issued only when the driving situation is critical i.e. the system has calculated that a collision is imminent in the next few seconds. Thus, even in London traffic they should go off far less frequently than proximity warnings. In this case, it is necessary for the warnings to be urgent and intrusive because they must quickly grab the attention of the driver and provoke rapid action to prevent a collision. These intrusive warnings are far less likely to annoy the driver, firstly because they should be far less frequent than proximity warnings and secondly because if they are working well it should be possible for the driver to see the reason for the warning in the majority of instances. False or premature activations when either the system has misdiagnosed the situation or reacted too soon will undermine driver confidence in the system and should be minimised, though what constitutes 'too soon' or even 'false' is to some degree subjective and driver dependent.

As such warnings issued over more than one channel (e.g. audible and visual and/or haptic warnings that are felt such as vibrations) are desirable, and speech warnings are undesirable because they take a finite time to complete and the drivers take a finite amount of time to process and understand the warning. Visual warnings should be red and audible warnings sufficiently loud to be heard against the backdrop of engine/passenger noise etc.

## 2.5 Other alert/warning signals

It should be noted that the test and assessment protocol only considers information signals and collision warnings in relation to close proximity manoeuvring but system suppliers may offer such signals in other driving circumstances, for example in relation to lane departure or imminent collision with a vehicle ahead. The requirements of the Bus Vehicle Specification and the test and assessment protocol do not apply to these other functions but also do not prohibit them. You can have other functions on the vehicle if considered beneficial. However, operators should consider the same HMI principles in relation to these other warnings and consider driver workload, recognition and reaction issues in terms of how well the system



quick and correct response and avoids driver confusion. Having very similar anonymous bleeps in reaction to multiple different undesirable traffic situations is unlikely to maximise driver effectiveness in collision avoidance.

## 2.6 Signal directionality and workload

Systems that draw the driver's attention in the direction of the hazard are considered more desirable than those that do not. For example, a system detecting the proximity of a cyclist to the left of the bus might illuminate an amber visual warning at the left side of the bus. By contrast a system that issues an audible and visual collision warning at a point low down in the dashboard near the driver, actually draws driver attention away from the hazard and may well be less effective as a consequence and generally increase driver workload.

## 2.7 Intervention systems

Even with the best vision and a high quality warning, successful collision avoidance will still rely on the driver taking the correct course of action sufficiently quickly and is, therefore, not guaranteed. Intervention systems will act in the event that the driver does not make the correct avoidance action or makes it insufficiently quickly. There are also clear risks with intervention systems if, for example, they misdiagnose the situation and intervene when they should not.

At the time of drafting requirements, it should be noted that automated emergency braking systems that are active in low speed manoeuvres (i.e. <10 km/h), particularly during left or right turns, were not available for any vehicle type. Although it is known that prototypes are in development, technical challenges remain around sensor accuracy, sensor fields of view and brake build up times, so it is not clear when they would be available. These have therefore not been included in the bus safety standard. However, such systems are not prohibited and if they become available should be analysed, assessed and considered.

Collisions where the vehicle moves off from rest and hits a pedestrian immediately in front of the vehicle present a particular challenge. In HGVs they are thought to occur because of blind spots. Buses typically do not suffer from such blind spots but collisions do still occur, albeit relatively less frequently. One possible explanation for this is that the driver is legitimately looking over their shoulder to check it is clear to move out from a bus stop into traffic at the time they move off. A non-intrusive visual warning may or may not be sufficient to draw the attention of the driver to the hazard given how far away from the relevant direction they may be looking.

By definition, a collision warning can only activate once the vehicle first moves such that it is on a collision course. If the pedestrian is close to the front, this would be issued too late for the driver to react and stop before the collision, though it may still prevent runover by the wheels.

However, a system that detected the presence of a pedestrian and, for example, disabled the throttle, then a driver that had not seen the pedestrian would remain unable to move the vehicle. Given that the vehicle would at this time be stationary, and probably would have been for some time, then the risks of such an intervention are relatively low. In the event of a spurious activation, the procedure allows for a driver over-ride to prevent the vehicle being "frozen". The aim is that it should not



be so easy to activate that it could be done accidentally but not so complicated that the driver would forget how to do it. Driver over-ride should only be activated when the driver is absolutely confident there is no hazard immediately in front of the vehicle. The over-ride function should deactivate once the system determines that the detected hazard has been avoided.

## **3 Training**

### **3.1 For test houses**

Test houses accredited to undertake Euro NCAP AEB tests will have the skills and equipment required for these tests. Test houses without such accreditation will be required to demonstrate to TfL at their expense that they can achieve the same standard of testing as an accredited organisation.

### **3.2 Bus drivers**

Drivers should be familiarised with the system such that they know what any warnings mean and, where applicable, how to over-ride an intervention system and when to do so. They should also be trained to understand the circumstances where the system can help them and those where it can't, for example, if a system does not perform at night or in adverse weather.

### **3.3 Shift Supervisors**

Supervisors should also be familiar with systems such that they can answer any questions from drivers and recognise any problems that may require maintenance.

### **3.4 Bus maintenance engineers**

The engineers carrying out general bus maintenance should be aware of the location and details of the sensors and warning displays/tell tales. They should be trained in any routine maintenance required (e.g. keeping sensors clean, free from obstruction etc.) and how to fault find and repair the system.

## **4 Maintenance**

Operators are encouraged to establish what (if any) daily checks are required, and to plan for these additional operational costs.

## **5 Repair**

If the driver or anyone else reports a failure or a problem with the system this should be investigated and, if confirmed, repaired.



# Attachment 26: Pedal Application Error Assessment Protocol

---

## 1 Introduction

This document presents a procedure for objectively assessing the performance of systems designed to stop incidents of pedal application error from occurring and to aid recovery from pedal application error.

### 1.1 Scope

This protocol applies to all new buses intended for service under contract to TfL that are passenger vehicles with a maximum mass exceeding 5 tonnes and a capacity exceeding 22 passengers. The passenger vehicles will be capable of carrying seated but unrestrained occupants and standing occupants. Such vehicles are categorised the Consolidated Resolution on the Construction of Vehicles (R.E.3) as M<sub>3</sub>; Class I, Class II.

The pedal acoustic feedback assessment shall only apply to quiet running buses with a hybrid (HEV), pure electric (PEV), electrified vehicle (EV), fuel cell vehicle (FCV) or a fuel cell hybrid vehicle (FCHV) drivetrain.

### 1.2 Purpose

The purpose of this assessment is to provide data from a controlled and repeatable test that can be used to assess the potential benefits (reduced casualties and damage) of a system to minimise pedal application error incidents, namely:

- The misapplication of the accelerator pedal; or
- The failure of the drivers to realise that they have applied the incorrect pedal.

In addition to measuring aspects of vehicle dynamics, the protocol provides a method for measuring how the system affects driver performance and how drivers interact with and understand the system.



## 2 Normative references

The following normative documents, in whole or in part, are referenced in this document and are indispensable for its application. For dated references, only the edition cited applies. For undated references, the latest edition of the referenced document (including any amendments) applies.

- UNECE Regulation No, 121 - Uniform Provisions Concerning the Approval of: Vehicles with Regard to the Location and Identification of Hand Controls, Tell-tales and Indicators
- ISO 2575:2004 – Road Vehicles – Symbols for controls, indicators and tell-tales.
- NHTSA Human Factors Design Guidance for Driver-Vehicle Interfaces (DOT HS 812 360).



### 3 Definitions

For the purpose of this Protocol:

- **Approval Authority** – the body within TfL that certifies that a bus is approved for use in the TfL fleet and assigns its score under the Bus Safety Standard for use in procurement processes.
- **BTS: Brake Toggle System** – a system that requires an extra brake press in order to release the halt brake after the bus doors have opened or the passenger ramp has been lowered.
- **ALS: Accelerator Light System** – a light system to inform the driver which pedal is currently being pressed.
- **CAN bus: Controller Area Network bus** – a vehicle bus standard to allow communication between microcontrollers and devices in applications without a host computer.
- **Halt Brake** – an automated braking system that prevents a bus from moving under certain conditions (e.g. when the bus doors are open or the bus ramp is lowered).
- **New Build** – a vehicle that has been built by the Vehicle Manufacturer with the system to be assessed fitted during the assembly process prior to first registration of the vehicle.
- **Pedal Application Error** – an incident where a driver mistakenly presses the accelerator pedal instead of the brake pedal.
- **Pedal Acoustic Feedback System** – a system fitted on quiet running buses that provides an acoustic feedback to the driver as to the acceleration and change of acceleration of the bus as determined by pedal usage, in order to help the driver recover from pedal confusion incident.
- **Retrofit** – fitment of the system to be assessed after the first registration of the vehicle. Installation is may be completed by the Vehicle Manufacturer or an authorised fitter.
- **Test Service** – The organisation undertaking the testing and certifying the results to the Approval Authority.
- **VUT: Vehicle Under Test** – means a vehicle that is being tested to this protocol.

### 4 Test conditions



## 4.1 Test Track

- 4.1.1 Testing shall be conducted on solid-paved road surfaces, with only a small amount of surface moisture, ice or other environmental factors that could reduce surface adhesion permitted.
- 4.1.2 The road surface shall not contain any major irregularities such as large pot holes or cracks in the road surface that may affect the behaviour of the driver (e.g. forcing them to take avoiding action) or have a physical impact on them (e.g. disturbing their foot and body position by causing them to move around excessively in their seat).
- 4.1.3 There shall be no obstructions in front of or behind the VUT for a distance of 10m. There shall be an area of free space of 3m to either side of the VUT.

## 4.2 Weather and lighting

- 4.2.1 Testing shall be conducted in clear and dry weather conditions with no precipitation falling and temperatures no lower than 5°C and not higher than 40°C.
- 4.2.2 Testing shall be conducted in both daytime and night time lighting conditions:
  - a) For daytime testing, natural ambient illumination shall be homogenous in the test area and in excess of 2000 lux. Testing shall not be performed driving towards, or away from the sun when there is direct sunlight.
  - b) For night-time testing, natural ambient illumination shall be homogenous in the test area and should not be in excess of 20 lux.



## **5 Vehicle preparation**

- 5.1 The VUT shall be prepared according to the following requirements:
- 5.1.1 The pedal application error systems shall have been installed during manufacture in the case of a new-build vehicle or retrofitted by qualified fitter authorised by the Vehicle Manufacturer; and
- 5.1.2 The VUT shall:
- a) Have passed a DVSA approved Periodic Technical Inspection within the last 12 months (if the vehicle is more than 12 months old) or passed an equivalent inspection if unregistered;
  - b) Be within its scheduled maintenance period (unless it is a new vehicle that has not yet been required to have its first service);
  - c) Have no faults or damage that could interfere with the testing protocol;
  - d) Have a halt brake system the engages when the bus doors are opened and when the passenger ramp is lowered;
  - e) Be driven by a qualified driver; and
  - f) Be empty of passengers or any persons other than the driver.



## 6 Test procedure

### 6.1 BTS

6.1.1 Apply the BTS checklist as defined in Annex 1 in the following sequence:

- a) Put the VUT into the specified state;
- b) Observe the result;
- c) Compare the observed result to required result; and
- d) Record if observed result matches required result (“Pass” or “Fail”).

### 6.2 ALS

6.2.1 Apply the ALS checklist as defined in Annex 1 in the following sequence:

- a) Put the VUT into the specified state;
- b) Observe the result;
- c) Compare observed result to required result; and
- d) Record if observed result matches required result (“Pass” or “Fail”).

6.2.2 The assessment of the ALS shall be completed under the following lighting conditions:

- a) Daylight; and
- b) Night time.

See section 4.2 for definition of lighting conditions.

6.2.3 Apply the lamp installation/illumination checklist as defined in Annex 2

6.2.3.1 The speed of activation of the lamps shall be assessed using high speed video analysis.

- a) The frame rate for the video shall be at least 1000 frames per second.
- b) The high speed video shall be synchronised with the CAN signal from the pedals.

6.2.3.2 The delay between the first movement of the pedal and the lamp achieving 90% of its steady state output shall be recorded.

### 6.3 Pedal acoustic feedback

6.3.1 Apply the pedal acoustic feedback checklist as defined in Annex 3.

6.3.1.1 This test shall only apply for quiet running vehicles including a hybrid (HEV), pure electric (PEV), electrified vehicle (EV), fuel cell vehicle (FCV) or a fuel cell hybrid vehicle (FCHV) drivetrain.



## 7 Assessment of results

7.1 The following criteria will be used to assess if the BTS and ALS have passed or failed the assessment.

### 7.1.1 BTS

7.1.1.1 In order to receive a “Pass” certification the system must receive a “Pass” grade for each of the requirements on the assessment checklist.

7.1.1.2 The system shall be deemed to have failed the assessment if it received a single “Fail” grade on the BTS assessment checklist.

### 7.1.2 ALS

7.1.2.1 In order to receive a “Pass” certification the system must receive a “Pass” grade for each of the requirements on the assessment checklist.

7.1.2.2 The system shall be deemed to have failed the assessment if it received a single “Fail” grade on the ALS assessment checklist.

### 7.1.3 Lamp installation/illumination checklist

7.1.3.1 In order to receive a “Pass” certification the system must receive a “Pass” grade for each of the requirements on the assessment checklist.

7.1.3.2 The system shall be deemed to have failed the assessment if it received a single “Fail” grade on the assessment checklist.

7.1.3.3 The lamp activation time shall be 100ms or less.

### 7.1.4 Pedal acoustic feedback checklist

7.1.4.1 Evidence shall be submitted by the bus manufacturer, or a bus inspected. The test engineer shall assess whether the bus passes or fails each check.

### 7.1.5 Overall Assessment

7.1.5.1 In order to receive an overall “Pass” certification the system must receive a “Pass” grade for each of the above sections on the checklist and have a lamp activation time of 100ms or less.

7.1.5.2 The system shall receive an overall “Fail” grade in the assessment if a single “Fail” grade was awarded on any section of the assessment checklist or if the lamp activation time is more than 100ms.

7.1.5.3 To integrate this pass/fail test into the overall bus safety score an overall Pass will be deemed as a score of 100% and a fail will be deemed a score of 0%



## 8 Test report

- 8.1 The Test Service shall provide a comprehensive test report that will be made available to the Approval Authority. The test report shall consist of the following distinct sections:
- a) Completed BTS checklist;
  - b) Completed ALS checklist;
  - c) Completed lamp installation/illumination checklist;
  - d) Lamp activation assessment;
  - e) Pedal acoustic feedback checklist; and
  - f) Reference information.
- 8.2 The reference information required shall include as a minimum:
- a) Vehicle make;
  - b) Vehicle model;
  - c) Vehicle model variant;
  - d) Pedal application error system installed (New-build/Retrofit);
  - e) Evidence of meeting vehicle preparation requirements (e.g. MOT certificate, service history);
  - f) Details of the Test Service; and
  - g) Test date(s).



# Annex 1 Brake toggle system checklist

## Brake Toggle System Checklist

Step	Bus State (On/Off)	Gear	Park Brake	Bus Doors	Action	Required Outcome	Actual Outcome	Outcome match? (Yes=1, No=0)
1	On	Drive	On	Closed	Open all bus doors	Halt brake engages		
2	On	Drive	Off	Closed	Apply accelerator	Halt brake remains engaged and bus does not move		
3	On	Drive	Off	Closed	Depress brake pedal to level that triggers brake lights on, and then release brake pedal	Halt brake releases		
4	On	Drive	Off	Closed	Apply accelerator	Bus moves forward		
5	On	Drive	On	Closed	Open all bus doors	Halt brake engages		
6	On	Drive	Off	Closed	Depress brake pedal to level that triggers brake lights on, and then release brake pedal	Delay of no more than 500ms before halt brake releases		
Total Required Score Outcome								6



## Annex 2 Accelerator light system checklist

### Accelerator Light System Checklist

Step	Bus State (On/Off)	Gear	Park Brake	Bus Doors	Action	Required Outcome	Actual Outcome	Outcome match? (Yes=1, No=0)
1	On	Drive	Off	Closed	Neither pedal pressed	Light is unlit when neither pedal is pressed		
2	On	Drive	Off	Closed	Brake pedal pressed	Light is unlit when brake pedal is pressed		
3	On	Drive	Off	Closed	Accelerator pedal pressed <80%	Light unlit		
4	On	Drive	Off	Closed	Accelerator pedal pressed >80%	No noticeable delay in light turning on		
5	On	Drive	Off	Closed	Accelerator pedal pressed >80%	Light illuminated		
6	On	Drive	Off	Closed	Accelerator pedal pressed <80%	No noticeable delay in light turning off		
7	On	Drive	Off	Closed	Accelerator pedal pressed >80%	No visible flickering of lights		
8	On	Drive	Off	Closed	Brake pedal pressed	No noticeable delay in light turning off		
9	Pn	Drive	Off	Closed	Accelerator pedal pressed	No noticeable delay in light illuminating		
Total Required Score Outcome								9



### Annex 3 Lamp installation/illumination checklist

#### Lamp installation/illumination Checklist

Step	Bus State (On/Off)	Gear	Park Brake	Bus Doors	Action	Required Outcome	Actual Outcome	Outcome match? (Yes=1, No=0)
1	On	Neutral	On	Closed	Accelerator pedal pressed	Lights meet requirements of UN Regulation 121 Sections 5.2.2 5.2.4 5.4.2 and 5.4.3		
2	On	Neutral	On	Closed	Accelerator pedal pressed	Lights meet requirements of ISO 2575:2004 Section 4 and Section 5		
3	On	Neutral	On	Closed	Accelerator pedal pressed	Lights meet UN ECE Regulation 121		
Total Required Score Outcome								3



## Annex 4 Pedal acoustic feedback checklist

### Pedal Acoustic Feedback checklist

Acoustic feedback	Expected Outcome	Actual Outcome	Outcome match? (Yes=1, No=0)
The feedback system shall have a master volume control that can only be set by the bus manufacturer to prevent increasing the noise levels inside the saloon of the bus	Pass		
The level set by the manufacturer shall be audible by the driver and not cause undue annoyance. (Levels to be defined by testing using ISO 5128 -1980 (E); Acoustics - Measurement of Noise inside Motor Vehicle).	Pass		
A local Driver volume control shall also be incorporated that will allow the driver to reduce the volume of the system to a pre set minimum level (not to switch off) and also not increase the volume beyond the manufacturers pre-set point.	Pass		
The feedback speaker(s) should be mounted behind the drivers head area at ear height.	Pass		
When installing/positioning the feedback speaker(s) care must be taken as to not have a detrimental effect on head movement during the operation of the bus and in the case of a collision the head being able to strike hard objects.	Pass		
Total Required Score Outcome			5



# Attachment 27: Pedal Application Error

## Guidance Notes

---

### 1 Introduction

This document sets out the guidance notes related to pedal application error. These guidance notes are aimed at bus operators and manufacturers as a practical guide for implementation of the Bus Safety Standard.

These notes are for guidance only, and are not legally binding. In all circumstances, the guidance provided by a manufacturer of the bus or system shall take precedence, and these guidance notes are only for use in the absence of other information. These are not intended to be exhaustive, but to point the operators toward practical advice and questions to raise with manufacturers/suppliers.

### 2 Selection of buses/systems

Any bus that meets the TfL Bus Vehicle Specification.

The Bus Safety Standard contains several systems intended to reduce the likelihood and consequence of errors in pedal choice between the brake and accelerator:

- Pedal toggling – a system in which the brake pedal must be fully depressed and released before moving off after closing the doors
- Accelerator light indicator– a system that gives the driver a visual indication of the accelerator pedal being pressed via a light on the dashboard
- Pedal acoustic feedback system – a system that gives the driver an audible cue as to the use of pedals and the change of acceleration of the bus, in order to help with recovery from a pedal confusional incident.

#### 2.1 Brake toggling

##### 2.1.1 *Bus selection*

In order for this system to be retrofitted onto buses, the buses must have a halt brake system that operates when the bus doors are opened (as well as when the passenger ramp is lowered). Therefore, vehicles with such a system should be procured.

##### 2.1.2 *System Selection*

A brake toggling system that requires the driver to press the brake pedal in order to release the halt brake should be selected. The halt brake should only engage after the bus doors have been opened or the passenger ramp has been lowered, with the brake press to release the halt brake only intended to operate when drivers are



leaving bus stops or starting their shift. A comparison between the task order for the brake reminder system and standard bus operation is detailed in Table 1 below.

**Table 1. Comparison of task order between standard operation and the brake toggle system**

Standard Bus Task Order	Brake Toggle Task Order
Press brake	Press brake
Change gear to “D”	Change gear to “D”
Release brake	Release brake
-	Press brake
-	Release brake
Release park brake	Release park brake
Apply accelerator	Apply accelerator

## 2.2 Brake/accelerator indicator lights

### 2.2.1 Bus selection

It may be easier to integrate the accelerator light into buses with LCD screens on the dashboard.

### 2.2.2 System selection

The accelerator indicator light system should be designed in such a way that it conforms to UN ECE Regulation 121. This makes reference to ISO 2575:2004, which should be used as additional guidance if needed. If further guidance is still needed then the guidance set out in the NHTSA Human Factors Design Guidance For Driver Vehicle Interfaces (DOT HS 812 360) may be referenced as a third option. UN ECE Regulation 121 takes precedence in all cases.

The requirements for the design and installation of the accelerator light system are contained within the requirements of the EC Whole Vehicle Type Approval for any tell-tale or indicator fitted to passenger or goods vehicles. These are provided in UN ECE Regulation 121 - Uniform Provisions Concerning the Approval of: Vehicles with Regard to the Location and Identification of Hand Controls, Tell-tales and Indicators. Regulation 121 prescribes the location, identification, colour, and illumination of common controls as well as the requirements for access and visibility

The visual indicator showing the driver when the accelerator is pressed is not included within the list of common items or controls covered by the Regulation. Where a tell-tale or indicator for which the Regulation does not provide specific provisions is installed on a vehicle certain requirements shall be adhered to. These requirements, taken from Sections 5 and 6 of Regulation 121, are summarised below:

#### 2.2.2.1 Identification:

- a) Where possible a symbol designated for the purpose in ISO 2575:2010
  - Road vehicles — Symbols for controls, indicators and tell-tales, shall



- b) To identify a tell-tale or indicator not included in the Regulation or ISO 2575:2004 the manufacturer may use a symbol of its own conception. Such symbols may include internationally recognised alphabetic or numeric indications.
- c) Where a symbol is designed by a manufacturer the principles of Paragraph 4 of ISO 2575:2010 shall be followed.
- d) Any additional symbol used by the manufacturer shall not cause confusion with any symbol specified in the Regulation.

#### 2.2.2.2 Colour:

- a) Indicators and tell-tales not included in the Regulation or ISO 2575:2010 may be of any colour chosen by the manufacturer, however, such colour shall not interfere with or mask the identification of any tell-tale, control, or indicator specified in the Regulation.
- b) The colour to be selected shall follow the guidelines specified in Paragraph 5 of ISO 2575:2010.
- c) Each symbol used for identification of tell-tale or indicator shall stand out clearly against the background.
- d) The accelerator light system selected must adhere to these criteria.

## 2.3 Pedal acoustic feedback

### 2.3.1 Bus selection

This system is only required on quiet running buses with a hybrid (HEV), pure electric (PEV), electrified vehicle (EV), fuel cell vehicle (FCV) or a fuel cell hybrid vehicle (FCHV) drivetrain.

### 2.3.2 System Selection

No prototype or production versions of this system yet exist. Consultation with the bus manufacturers and TfL is needed before selecting buses.

## 3 Training

Usage of the pedal confusion solutions will require the creation of a training course to teach drivers about the solutions and how they operate. If feasible schedules should minimise drivers experience of mix of vehicles with and without the system. The determination for whether or not a driver is able to safely use the systems shall be up to the discretion of the bus operator and any assessment criteria they decide upon.

### 3.1 Brake Toggle

As the brake toggle solution involves a change to the driving tasks that drivers will have been trained to undertake and may have used for extended periods of time, some form of training with the system will be necessary.



In order to train drivers to use the brake toggle solution, it is recommended that drivers are first given a set of written instructions that explain how the system operates. The drivers shall then be given an oral explanation of how the system works from an instructor who is experienced at using the system. The driver shall then be given the opportunity to practise driving the bus on a private road. The driver shall first practice moving the bus from a standstill, imitating letting passengers on and off the bus by opening the bus doors and lowering the passenger ramp. Once the driver is comfortable using the system, they shall be given the opportunity to drive the bus on public roads. Ideally they will drive their normal bus route, stopping at bus stops along the way to practise moving off with the new brake interlock.

The instructor shall be responsible for determining if the driver is able to use the system based on how many errors they make and how long it takes them to deactivate the halt brake and drive away from the bus stops. There shall also be a small written examination that asks the driver basic questions regarding the brake toggle system, what the driver needs to do to operate the system and how their driving tasks will differ from what they are used to as a result of the system.

### **3.2 Accelerator Light System**

Drivers are to be trained with the accelerator light system in conjunction with the brake toggle system, with the same training protocol applied. As with the brake toggle system, written and oral instructions will be provided to drivers, who will then drive the bus on private and public roads in order to familiarise themselves with the system. The instructor will then determine if the driver is able to safely use the system based on the number of errors they make and the time it takes them to move off from bus stops. A short written examination will also be employed to determine how well the driver understands the system.

### **3.3 Pedal acoustic feedback**

The training for this system can be integrated with the other systems as above, with the same training protocol applied.

## **4 Maintenance**

Maintenance shall only be undertaken by authorised and qualified individuals using OEM approved procedures. Maintenance of the systems should be incorporated into the regular servicing schedules for the bus.

### **4.1 Brake Toggle**

Maintenance of the brake toggle system consists of maintaining the software that controls the bus interlock system as well as the halt brake system.

The software that is responsible for operating the bus interlock system must be regularly checked as part of the regular vehicle service schedule. The software must be checked in order to see that the halt brake is only activated upon the opening of the bus doors or the lowering of the passenger ramp, and that the halt brake can only be released after the brake has been fully depressed. It must also be ensured



interlock system by allowing the halt brake to activate and deactivate in an incorrect manner. In order to ensure that the brake toggle system works as intended, the halt brake itself must undergo regular checks as part of the service schedule for the bus.

A maintenance check for the brake toggle system should consist of checking that opening the bus doors and lowering the passenger ramp activates the halt brake, and that the halt brake cannot be deactivated without the brake pedal being fully depressed. A software check should also be carried out in order to ensure that the system is operating correctly.

## 4.2 Accelerator Light System

Maintenance of the accelerator light system should form part of the regular service schedule for the vehicle.

The light must be checked to see that there is no visible flicker when it illuminates and that there is no perceptible delay between the accelerator pedal being pressed and the corresponding lights activating. The light should also be checked to make sure that the correct colour is associated with the accelerator pedal press. A check should also be made to see that the light does not illuminate when neither of the pedals are being pressed. If the light is built into an LCD display then the software that operates the screen must be regularly checked. Visual inspections must also be carried out in order to ensure that there are no dead pixels or artefacts.

A maintenance check for the accelerator light system should consist of a visual inspection of the lights while the accelerator pedal is being pressed. A software check should also be carried out.

## 4.3 Pedal acoustic feedback system

Maintenance of the pedal acoustic feedback system should form part of the regular service schedule for the vehicle.

The speakers must be checked to see that there is no obscuration or damage, and to check that there is no perceptible delay between the accelerator pedal being pressed and the corresponding sound changing frequency. A check should also be made to listen for the sound changing frequency as the accelerator pedal is released, and that the sound remains constant if the pedal pressure is also constant.

## 5 Repair

Repairs shall only be undertaken by authorised and qualified individuals using OEM approved parts and procedures. If the systems were retrofitted then the guidelines set out by the post-homologation manufacturer shall be followed.

Advice should be sought from the manufacturers of the specific systems fitted to buses in service regarding precautions to be taken in the event of a system failure. However, as these systems are safety aids rather than safety critical systems for the bus, the failure of these systems should not normally render the bus unroadworthy. Repairs to the systems should be made as soon as operationally possible.



## 5.1 Brake Toggle

If a failure occurs to the brake toggle system due to a software error, then an appropriate software fix shall be implemented. The bus OEM (or post-homologation parts manufacturer in the case that the systems were retrofitted) should be consulted to diagnose the software fault and they shall then issue a fix to resolve the fault. The bus operator should not attempt to diagnose and fix the issue without consulting the bus OEM and seeking their assistance as incorrect software changes could affect the functioning of the halt brake.

Any faults that occur with halt brake system shall be repaired following the normal repair guidelines set out by the bus OEM.

## 5.2 Accelerator Light System

In the event that the accelerator light system becomes faulty due to a software issue then the bus OEM (or post-homologation parts manufacturer) should be consulted to diagnose the software fault and they shall then issue a fix to resolve the fault. Any physical issues with the lights shall be resolved by replacing the lights with approved parts. If the operation of dashboard lights fitted within an LCD screen is compromised due to some fault with the screen itself, e.g. dead pixels, poor contrast or brightness, then the bus OEM or supplier of the screen should be consulted for repair instructions.

## 5.3 Pedal acoustic feedback system

In the event that the pedal acoustic feedback system becomes faulty due to a software issue then the bus OEM (or post-homologation parts manufacturer) should be consulted to diagnose the software fault and they shall then issue a fix to resolve the fault. Any physical issues with the speakers shall be resolved by replacing the speakers with approved parts.



# Attachment 28: Runaway Bus Prevention Assessment Protocol

---

## 1 Introduction

This document presents a procedure for objectively assessing the performance of systems installed on a bus to prevent the bus rolling in an uncontrolled manner without input from a driver; the occurrence of which would be known as a “runaway event” or “runaway bus”.

### 1.1 Scope

This protocol applies to all new buses intended for service under contract to TfL that are passenger vehicles with a maximum mass exceeding 5 tonnes and a capacity exceeding 22 passengers. The passenger vehicles will be capable of carrying seated but unrestrained occupants and standing occupants. Such vehicles are categorised the Consolidated Resolution on the Construction of Vehicles (R.E.3) as M<sub>3</sub>; Class I, Class II.

### 1.2 Purpose

The purpose of this assessment is to provide an expected level of performance for systems that claim to prevent runaway bus occurrences.

## 2 Normative References

The following normative documents, in whole or in part, are referenced in this document and are indispensable for its application. For dated references, only the edition cited applies. For undated references, the latest edition of the referenced document (including any amendments) applies.

- London Bus Services Limited Guidance Notes: Runaway Bus Prevention



### 3 Definitions

For the purpose of this Protocol:

- **Approval Authority** – the body within TfL that certifies that a bus is approved for use in the TfL fleet and assigns its score under the Bus Safety Standard for use in procurement processes.
- **Halt Brake** – an automated braking system that prevents a bus from moving under certain conditions (e.g. when the bus doors are open or the bus ramp is lowered).
- **New Build** – a vehicle that has been built by the Vehicle Manufacturer with the system to be assessed fitted during the assembly process prior to first registration of the vehicle.
- **Park Brake** – brake system that is intended to keep the vehicle stationary when parked.
- **RaB: Runaway Bus** – a bus without the park brake engaged that moves in any direction in an uncontrolled manner without any input from a driver
- **Test Service** – The organisation undertaking the testing and certifying the results to the Approval Authority.
- **VUT: Vehicle Under Test** – means a vehicle that is being tested to this protocol.



## **4 Test conditions**

### **4.1 Test track**

- 4.1.1 Testing shall be conducted on dry (no surface moisture, ice or other environmental factors that could reduce surface adhesion) and solid-paved road surfaces.
- 4.1.2 The test track shall have a gradient of between 1% and a 5%.
- 4.1.3 There shall be clear zone around the VUT. The clear zone shall extend at least one bus length in front of and behind the VUT, and one bus width to either side of the VUT, to give the required room for any rolling that occurs as a result of the testing.

### **4.2 Weather and lighting**

- 4.2.1 Testing shall be conducted in clear and dry weather conditions with no precipitation falling and temperatures no lower than 5°C and not higher than 40°C. As an alternative the tests may be conducted indoors.
- 4.2.2 The test track shall have a level of ambient light that will allow the driver and assessor to see if any people or objects move into positions where they could be a risk of being hit by the bus during testing.



## 5 Vehicle preparation

5.1 The RaB bus preventions system shall:

- a) Have been installed during manufacture in the case of a new-build vehicle; and
- b) Interact with the park brake and not the halt brake to ensure system functionality in the event that the halt brake has no air pressure in it (whether through a malfunction or because the bus is switched off and the brake pressure has released).

5.1.1 **The VUT shall:**

- a) Have passed its mandatory Periodic Technical Inspection at a DVSA approved facility within the last 12 months (if the vehicle is more than 12 months old), with the exception of prototype vehicles;
- b) Be within its scheduled maintenance period (unless it is a new vehicle that has not yet been required to have its first service);
- c) Have no faults or damage that could interfere with the testing protocol. The brakes shall have been checked by the driver to ensure that the bus can be stopped manually during testing in the event that the bus does roll;
- d) Have a halt brake system the engages when the bus doors are opened and when the passenger ramp is lowered;
- e) Have checked all passenger doors on the ground floor to ensure they are all fully operational;
- f) Be positioned on the test track of defined gradient to ensure that if the bus is not being held stationary by any mechanisms it will visibly roll in a way that is obvious to the assessor;
- g) Have no obstructions in front or behind any of its wheels;
- h) Be driven by a qualified driver. In the instances where the test procedure requires there be no seat pressure the driver shall remain within the drivers cabin to apply the brakes when the bus rolls; and
- i) Be empty of passengers or any persons other than the driver.



## **6 Test procedure**

6.1 The assessment of the RaB prevention system is carried out in two stages. The bus safety system checklist shall be completed prior to commencing the RaB prevention system checklist.

### **6.2 Bus safety system checklist**

6.2.1 Apply the bus safety system checklist as defined in Annex 1 in the following sequence:

- a) Put the VUT into the specified state;
- b) Observe the result;
- c) Compare the observed result to the required result;
- d) Record if observed result matches required result (“Pass” or “Fail”);
- e) Reset the position of the VUT if it has moved during the test; and
- f) Reset the gear to neutral.

### **6.3 RaB prevention system checklist**

6.3.1 If all requirements of the bus safety system checklist are satisfied, apply the RaB prevention system checklist as defined in Annex 2 in the following sequence:

- a) Put the VUT into the specified state;
- b) Observe the result;
- c) Compare the observed result to the required result;
- d) Record if observed result matches required result (“Pass” or “Fail”);
- e) Reset the position of the VUT if it has moved during the test; and
- f) Reset the gear to neutral.



## 7 Assessment of results

7.1 The following criteria will be used to assess if the RaB prevention system has passed or failed the assessment.

### 7.1.1 Pre-requisites

- a) In order to receive a “Pass” certification, the system must meet the expected outcome for each of the requirements on the bus safety system assessment checklist.
- b) The system shall be deemed to have failed the assessment if it does not meet a single expected outcome on the bus safety assessment checklist. A system that fails to meet these pre-requisites shall not be recommended.

### 7.1.2 Assessment of the RaB prevention system

- a) In order to receive a “Pass” certification the system must meet the expected outcome for each of the requirements on the RaB prevention system checklist.
- b) The system shall be deemed to have failed the assessment if it does not meet a single expected outcome on the RaB prevention system checklist.

### 7.1.3 Overall Assessment

- a) In order to receive an overall “Pass” certification the system must receive a “Pass” grade for each of the above sections on the checklist
- b) The system shall receive an overall “Fail” grade in the assessment if a single “Fail” grade was awarded on any section of the assessment checklist.
- c) To integrate this pass/fail test into the overall bus safety score an overall Pass will be deemed as a score of 100% and a fail will be deemed a score of 0%.



## 8 Test report

- 8.1 The Test Service shall provide a comprehensive test report that will be made available to the Approval Authority. The test report shall consist of three distinct sections:
- a) Completed bus safety system checklist;
  - b) Completed RaB prevention system checklist; and
- 8.2 Reference information.
- 8.3 The reference information required shall include as a minimum:
- a) Vehicle Make;
  - b) Vehicle Model;
  - c) Vehicle Model Variant;
  - d) RaB system installed;
  - e) Evidence of meeting vehicle preparation requirements (e.g. MOT certificate, service history);
  - f) Details of the Test Service; and
  - g) Test date(s).



**Annex 1 Runaway bus safety system checklist**

Runaway Bus Prevention			General Braking Mechanisms		Break Down	Expected Outcome	Actual Outcome	Outcome match? (Yes=1, No=0)
Drive enabled (Is the bus "on"?)	Gear	Seat Pressure / Driver Input	Park Brake	Passenger Door	Kill Switch			
No	Neutral	Yes	Off	Closed	Disengaged	Roll		
No	Neutral	Yes	On	Closed	Disengaged	No roll		
<b>No</b>	<b>Neutral</b>	<b>No</b>	<b>Off</b>	<b>Closed</b>	<b>Engage</b>	<b>Roll</b>		
Yes	Neutral	Yes	Off	Closed	Disengaged	Roll		
Yes	Neutral	Yes	On	Closed	Disengaged	No roll		
<b>Yes</b>	<b>Neutral</b>	<b>No</b>	<b>Off</b>	<b>Closed</b>	<b>Engage</b>	<b>Roll</b>		
Yes	Reverse	Yes	Off	Closed	Disengaged	Roll		
Yes	Reverse	Yes	On	Closed	Disengaged	No roll		
<b>Yes</b>	<b>Reverse</b>	<b>No</b>	<b>Off</b>	<b>Closed</b>	<b>Engage</b>	<b>Roll</b>		
Yes	Drive	Yes	Off	Closed	Disengaged	Roll		
Yes	Drive	Yes	On	Closed	Disengaged	No roll		
<b>Yes</b>	<b>Drive</b>	<b>No</b>	<b>Off</b>	<b>Closed</b>	<b>Engage</b>	<b>Roll</b>		
						Total Required Score Outcome	12	



## Annex 2 Runaway bus prevention system checklist

Runaway Bus Prevention			General Braking Mechanisms		Expected Outcome	Actual Outcome	Outcome match? (Yes=1, No=0)
Drive enabled (Is the bus "on"?)	Gear	Seat Pressure / Driver Input	Park Brake	Passenger Door			
No	Neutral	Yes	Off	Open	No roll		
No	Neutral	No	Off	Closed	No roll		
No	Neutral	Yes	Off	Closed	Roll		
Yes	Neutral	Yes	Off	Open	No roll		
Yes	Neutral	No	Off	Closed	No roll		
Yes	Neutral	Yes	Off	Closed	Roll		
Yes	Reverse	Yes	Off	Open	No roll		
Yes	Reverse	No	Off	Closed	No roll		
Yes	Reverse	Yes	Off	Closed	Roll		
Yes	Drive	Yes	Off	Open	No roll		
Yes	Drive	No	Off	Closed	No roll		
Yes	Drive	Yes	Off	Closed	Roll		
Total Required Score Outcome							12

# Attachment 29: Runaway Bus Prevention Guidance Notes

---

## 1 Introduction

This document sets out the guidance notes related to runaway bus prevention. These guidance notes are aimed at bus operators and manufacturers as a practical guide for implementation of the Bus Safety Standard.

These notes are for guidance only, and are not legally binding. In all circumstances, the guidance provided by a manufacturer of the bus or system shall take precedence, and these guidance notes are only for use in the absence of other information. These are not intended to be exhaustive, but to point the operators toward practical advice and questions to raise with manufacturers/suppliers.

## 2 Selection of buses/systems/ testhouse

Any bus that meets the TfL Bus Vehicle Specification.

A runaway bus prevention system may be provided as a new build bus

The testing of the runaway prevention should be carried out by a TfL approved testhouse. In the case that testing is to be carried out by a test house that does not fall into the aforementioned category prior approval must be gained from TfL.

### 2.1 Compliance and warranty

A bus operator should ask to see compliance certificates for UNECE Regulation 13 and warranty information for the brake system from both the bus manufacturer and/or the system supplier. The bus operator must be able to present certificates to TfL as evidence that the bus brake system will continue to operate safely, and that the bus will not brake unexpectedly whilst in motion.

A bus manufacturer should work with any brake or runaway bus prevention system suppliers to ensure that UNECE Regulation 13 requirements are met, and that warranty on the brake system is maintained. The bus manufacturer must be able to present certificates to TfL as evidence that the bus brake system will continue to operate safely, and that the bus will not brake unexpectedly whilst in motion.

In the case that there are any functional changes made to the bus the vehicle should be re-tested (at the discretion of TfL) to make sure it still complies with the runaway bus assessment protocol.

### 2.2 Towing and recovery

The runaway bus prevention system is designed to keep the bus brakes on. Towing and recovery are the exceptions to this requirement and the bus needs to be able to roll without the driver in the seat.



UNECE Regulation 13 requires an auxiliary release system for the brakes to allow towing. These are often mechanical. Obviously, this should only be undertaken when the vehicle is held stationary by some other external means, e.g. wheel chocks or recovery vehicles etc., and is only intended for use in full breakdown/recovery circumstances. The Regulation permits powered auxiliary release systems but only if the energy source is different to that used by the brakes, e.g., it can't be operated from the same air supply such that the loss causing the problem also causes the release not to work. Bus drivers should be trained on how to use the auxiliary release.

## **3 Training**

### **3.1 Bus drivers**

The runaway bus prevention systems are only aimed at preventing rare occurrences where the handbrake has not been applied. The drivers don't necessarily need to be trained in exactly how the system works but do need to be informed that it will trigger in instances where the bus has been left vulnerable to rolling (without the park brake engaged). Drivers do however need to be trained in how to release the system once they have rectified the issue by engaging the park brake.

### **3.2 Shift Supervisors**

Shift supervisors should be trained in how the system works and know the code/sequence of actions to activate the system's auxiliary release. In the event that one of their drivers or engineers has engaged the system and doesn't understand how to disengage it, or require the code for the runaway prevention systems auxiliary release (for what the supervisor deems to be a legitimate reason) they will have the ability to facilitate the rectification of the situation.

### **3.3 Bus maintenance engineers**

The engineers carrying out general bus maintenance should be aware of how to activate the auxiliary release on the runaway prevention system should the maintenance they are carrying out requiring the bus to roll in a state where the runaway prevention system would otherwise inhibit that movement.

## **4 Maintenance**

One system supplier requires daily checks of the runaway bus prevention system and the sensors that the system makes use of. Operators are encouraged to establish what (if any) daily checks are required, and to plan for these additional operational costs.

## **5 Repair**

If during system maintenance checks (section 4) any of the sensors are deemed to be faulty or failing they should be replaced immediately. The runaway prevention



system's effectiveness and reliability is completely contingent on the performance of the sensors the system is connected to.



# Attachment 30: Acoustic Conspicuity

## Assessment Protocol

---

### 1 Introduction

This document presents a procedure for objectively assessing the performance of Acoustic Vehicle Alerting Systems (AVAS) installed on a bus. The aim of these systems is to make a quiet running vehicle (e.g. hybrid or electric) as conspicuous to a pedestrian as a typical diesel engine.

### 2 Scope

This protocol applies to all new buses intended for service under contract to TfL that are passenger vehicles with a maximum mass exceeding 5 tonnes and a capacity exceeding 22 passengers. The passenger vehicles will be capable of carrying seated but unrestrained occupants and standing occupants. Such vehicles are categorised in the Consolidated Resolution on the Construction of Vehicles (R.E.3) as M<sub>3</sub>; Class I, Class II.

### 3 Purpose

The purpose of this assessment is to provide an expected level of performance for AVAS.

### 4 Normative References

The following normative documents, in whole or in part, are referenced in this document and are indispensable for its application. For dated references, only the edition cited applies. For undated references, the latest edition of the referenced document (including any amendments) applies.

- London Bus Services Limited Guidance Notes: Acoustic Conspicuity
- UN ECE Regulation 138; Uniform provisions concerning the approval of Quiet Road Transport Vehicles with regard to their reduced audibility



## 5 Definitions

For the purpose of this Protocol:

- **Approval Authority** – the body within TfL that certifies that a bus is approved for use in the TfL fleet and assigns its score under the Bus Safety Standard for use in procurement processes.
- **AVAS** – Acoustic Vehicle Alerting System, as per Regulation 138.
- **New Build** – a vehicle that has been built by the Vehicle Manufacturer with the system to be assessed fitted during the assembly process prior to first registration of the vehicle.
- **Test Service** – The organisation undertaking the testing and certifying the results to the Approval Authority.
- **VUT: Vehicle Under Test** – means a vehicle that is being tested to this protocol.

## 6 Test conditions

### 6.1 Test track

6.2 Testing shall be conducted on dry (no surface moisture, ice, snow or other environmental factors that could affect acoustic performance..

6.3 The test **track** shall meet the requirements of ISO 10844.

### 6.4 Weather and lighting

6.5 Testing shall be conducted in clear and dry weather conditions with no precipitation falling and temperatures no lower than 5°C and not higher than 40°C. Wind speed shall be less than 5 m/s. As an alternative the tests may be conducted indoors.

6.6 The test track shall have a level of ambient light that will allow the driver and assessor to see if any people or objects move into positions where they could be a risk of being hit by the bus during testing.



## **7 Vehicle preparation**

- 7.1 The AVAS shall have been installed during manufacture in the case of a new-build vehicle.
- 7.2 The VUT shall:
- 7.3 Have passed an annual MOT test at a DVSA test station within the last 12 months (if the vehicle is more than 12 months old), with the exception of prototype vehicles;
  - a) Be within its scheduled maintenance period (unless it is a new vehicle that has not yet been required to have its first service);
  - b) Have no faults or damage that could interfere with the testing protocol;
  - c) Be driven by a qualified driver. In the instances where the test procedure requires there be no seat pressure the driver shall remain within the drivers cabin to apply the brakes when the bus rolls; and
  - d) Be empty of passengers or any persons other than the driver.

## **8 Test procedure**

- 8.1 The assessment of the AVAS is carried out using a checklist.
- 8.2 The AVAS checklist shall be assessed based on documentation submitted by the bus manufacturer.
- 8.3 Compare the observed result to the required result;
- 8.4 Record if observed result matches required result (“Pass” or “Fail”);

## **9 Assessment of results**

- 9.1 The following criteria will be used to assess if the AVAS system has passed or failed the assessment.
- 9.2 In order to receive a “Pass” certification, the system must meet the expected outcome for each of the requirements on the assessment checklist.
- 9.3 The system shall be deemed to have failed the assessment if it does not meet a single expected outcome on the AVAS assessment checklist. A system that fails to meet these pre-requisites shall not be recommended.



## **11 Test report**

- 11.1 The Test Service shall provide a comprehensive test report that will be made available to the Approval Authority. The test report shall consist of two distinct sections:
- a) Completed AVAS checklist;
  - b) Reference information.
- 11.2 The reference information required shall include as a minimum:
- a) Vehicle Make;
  - b) Vehicle Model;
  - c) Vehicle Model Variant;
  - d) AVAS system installed;
  - e) Evidence of meeting vehicle preparation requirements (e.g. technical inspection, service history);
  - f) Details of the Test Service; and
  - g) Test date(s).



**Annex 1 AVAS checklist**

<b>Acoustic Vehicle Alerting System (AVAS)</b>	<b>Expected Outcome</b>	<b>Actual Outcome</b>	<b>Outcome match? (Yes=1, No=0)</b>
2 channel directional system	Pass		
Speaker mounted with horizontal plane - up to a maximum [0.6] m either side of the centre line of the bus	Pass		
Speaker mounted with vertical plane - between [0.5 m] to [1.0 m] (Normally [0.8 m])	Pass		
The speaker(s) must have an unobstructed sound path.	Pass		
The speakers are mounted one on each side of the bus front	Pass		
Each speaker has a horizontal beamwidth/directivity pattern in the range [120° to 140°] and a vertical beamwidth/directivity pattern in the range [70° to 110°]	Pass		
The centre line of the speakers shall be aligned towards the nearside kerb at an angle of 20° to 30° from the front surface of the bus	Pass		
If the two speakers are playing the same sound, the sounds shall be incoherent to avoid interference patterns affecting conspicuity.	Pass		
AVAS sound is Regulation 138 compliant and a valid test certificate submitted	Pass		
TfL Urban bus sound, version 1.0 installed	Pass		
AVAS shall be capable of receiving an updated sound file in the future, e.g. as a minimum locally via USB, or optionally via telematics (mass update).	Pass		
A USB device must also be incorporated in to the AVAS to allow for local updates.	Pass		
The system shall have the capability to have at least 3 sounds stored on the system (one sound at installation / entry into service, then a further two additional sounds)	3 or more		
<b>Total Required Score Outcome</b>			<b>13</b>



# Attachment 31: Acoustic Conspicuity

## Guidance Notes

---

### 1 Introduction

This document sets out the guidance notes related to Acoustic Conspicuity. These guidance notes are aimed at bus operators and manufacturers as a practical guide for implementation of the Bus Safety Standard.

These notes are for guidance only, and are not legally binding. In all circumstances, the guidance provided by a manufacturer of the bus or system shall take precedence, and these guidance notes are only for use in the absence of other information. These are not intended to be exhaustive, but to point the operators toward practical advice and questions to raise with manufacturers/suppliers.

### 2 Selection of buses/systems

#### 2.1 Buses requiring Acoustic Conspicuity measures

Regulatory requirements are coming in to force for Whole Vehicle Type Approval (WVTA), in the form of Regulation 138<sup>24</sup>. This requires:

- From September 2019 all new bus models (new designs requiring type approval) in vehicle category M2 or M3 and fitted with either a hybrid (HEV), pure electric (PEV), electrified vehicle (EV), fuel cell vehicle (FCV) or a fuel cell hybrid vehicle (FCHV) drivetrain will be subject to having acoustic conspicuity measures installed.
- From September 2022 all new registered buses with drivetrains listed above will also be subject to having acoustic conspicuity measures installed.

TfL are requiring that all its new buses meet Regulation 138 from 2019, whether they go through WVTA or National Small Series Type Approval (NSSTA) or Individual Vehicle Approval (IVA).

TfL requires all new buses to have an Acoustic Vehicle Alerting System (AVAS) installed in accordance with Regulation 138. In particular the AVAS shall additionally meet some extra requirements, mainly around ability to emit the urban bus sound being designed by TfL, and that the noise should be updatable in the future.

#### 2.2 Acoustic Conspicuity measure

##### 2.2.1 AVAS (Acoustic Vehicle Alerting System)

---

<sup>24</sup> UN ECE Regulation 138; Uniform provisions concerning the approval of Quiet Road Transport Vehicles with regard to their reduced audibility.



A solution has been defined as 'added sound'; or what is currently referred to as an AVAS (Acoustic Vehicle Alerting System). This is an audible warning, active at low speed, indicating steady state, acceleration and deceleration conditions. Currently, systems are only active at speeds between 0 km/h to 30 km/h inclusive (the maximum speed within Europe is 20 km/h and 30 km/h for the US only), and are intended to replace engine noise cues to pedestrians and vulnerable road users (VRUs) that a vehicle is approaching.

A two channel AVAS should be selected; this will enable the sound sources to provide a fuller directional component towards the kerbside. The sound sources should be installed at the front of the bus (see specification for details of source height and direction). This should also be done in conjunction with the manufacturer of the AVAS equipment

Any AVAS chosen should be compliant with UNECE Regulation 138 (Uniform provisions concerning the approval of Quiet Road Transport Vehicles with regard to their reduced audibility - QRTV). Regulation 138 lays out the requirements for the minimum sound and defines the testing protocol. This document can be found at the following web address:

[www.unece.org/fileadmin/DAM/trans/main/wp29/wp29regs/2017/R138r1e.pdf](http://www.unece.org/fileadmin/DAM/trans/main/wp29/wp29regs/2017/R138r1e.pdf)

Thought will need to be given to the actual sound generated by the AVAS, as it is a balance between brand signature, enhancing detection and reducing environmental noise. Therefore, consultation with TfL is advised during the process of specifying any AVAS equipment.

TfL will be developing an urban bus sound for use on all buses across London. Partners are invited to collaborate on the development of this sound. The purpose is to minimise any risk of confusion that might arise if different bus models had different sounds. The sound will be made available to other urban areas and its use will not be restricted to London.

### **3 Training**

Once AVAS equipment is installed, there should be very little training required as the system is automatic and will operate between set speeds and adjust the sound for acceleration and deceleration via inputs from the CAN-Bus. However, individual manufacturers of the equipment will advise if any training is required.

### **4 Maintenance**

Once AVAS equipment is installed, there should be minimal maintenance required. However, as the system will be fitted within the front of the bus, regular inspection of the sound sources is recommended to keep them free of debris and to ensure that no damage has occurred.

Individual manufacturers of the equipment will advise if and what maintenance is required and will specify maintenance intervals.

### **5 Repair**

Any repairs that are required to the AVAS will need to be done in conjunction with the manufacturer of the equipment.

# Attachment 32: Slip Protection

## Assessment Protocol

---

### 1 Introduction

This document presents a procedure for the characterisation of the slip resistance properties of flooring materials for buses.

#### 1.1 Scope

This protocol applies to all new buses intended for service under contract to TfL that are passenger vehicles with a maximum mass exceeding 5 tonnes and a capacity exceeding 22 passengers. The passenger vehicles will be capable of carrying seated but unrestrained occupants and standing occupants. Such vehicles are categorised in the Consolidated Resolution on the Construction of Vehicles (R.E.3) as M<sub>3</sub>; Class I, Class II.

#### 1.2 Purpose

The purpose of this assessment is to characterise the slip risk associated with bus flooring materials by measuring and assessing the slip resistance of those materials. This is achieved by using a method adapted from the United Kingdom Slip Resistance Group (UKSRG) guidelines (The UK Slip Resistance Group, 2016) which uses the Portable Slip Resistance Tester (PSRT) as the measurement device.

### 2 Normative References

The following normative documents, in whole or in part, are referenced in this document and are indispensable for its application. For dated references, only the edition cited applies. For undated references, the latest edition of the referenced document (including any amendments) applies.

British Standards Institution. (2002). *BS 7976-2:2002 Pendulum testers - Part 2: Method of operation*. London: BSi.

British Standards Institution. (2011). *BS EN 13036-4. Road and airfield surface characteristics. Test methods. Method for measurement of slip/skid resistance of a surface. The pendulum test*. London: BSi.

British Standards Institution. (2013). *BS 7976-1:2002+A1:2013 Pendulum testers - Part 1: Specification*. London: BSi.

British Standards Institution. (2013). *BS 7976-3:2002+A1:2013 Pendulum testers - method of calibration*. London: BSi.

The UK Slip Resistance Group. (2016). *The assessment of floor slip resistance - The UK slip resistance group guidelines*. UKSRG.



### 3 Definitions

For the purpose of this Protocol:

- **Approval Authority** – the body within TfL that certifies that a bus is approved for use in the TfL fleet and assigns its score under the Bus Safety Standard for use in procurement processes.
- **IHRD: International Rubber Hardness Degrees** – method for measuring the hardness of rubber.
- **PSRT: Portable Slip Resistance Tester** – standard laboratory testing device for measuring slip resistance in the UK, defined by British Standards.
- **PTV: Pendulum Test Value** – measurement recorded by the PSRT
- **UKAS: United Kingdom Accreditation Service** – the UK's national accreditation body.
- **UKSRG: United Kingdom Slip Resistance Group** – independent authority of slip resistance.
- **Test Service** – The organisation undertaking the testing and certifying the results to the Approval Authority.
- **VUT: Vehicle Under Test** – means a vehicle that is being tested to this protocol.

### 4 Test equipment and conditions

#### 4.1 Test equipment

4.1.1 The measurement device used in this protocol is the PSRT as defined by the following British Standards:

- BS 7976-1:2002+A1:2013 (British Standards Institution, 2013)
- BS 7976-2:2002 (British Standards Institution, 2002)
- BS 7976-1:2003+A1:2013 (British Standards Institution, 2013)

#### 4.2 Test conditions

4.2.1 All tests shall be completed in a test environment where the temperature is between 5°C to 40°C. This requirement is in addition to UKSRG guidelines (The UK Slip Resistance Group, 2016))

4.2.2 Tests shall only be made under wet conditions. This requirement supersedes Section 3.6 of the UKSRG guidelines (The UK Slip Resistance Group, 2016))



## 5 Test procedure

- 5.1 Apply the UKSRG guidelines for measuring slip resistance using the PSRT, with the following amendments:
- 5.2 Test shall be carried out in a test environment with a temperature range of 5°C to 40°C. (Addition to UKSRG guidelines (The UK Slip Resistance Group, 2016))
- 5.3 Tests shall only be made under wet conditions. (Supersedes Section 3.6 of the UKSRG guidelines (The UK Slip Resistance Group, 2016))
- 5.4 During one test sequence, repeat measurements shall be made until the difference between the smallest and largest of five consecutive measurements is less than or equal to 3 (i.e.  $PTV_{Max} - PTV_{MIN} \leq 3$ ). The mean of these 5 consecutive measurements is the average PTV. (Supersedes Section 3.6, Point 9 and 10 of the UKSRG guidelines (The UK Slip Resistance Group, 2016)).
- 5.5 For each test specimen, sequence of tests shall be completed for each of the following directions, note 0° is defined as the main direction of travel of passengers:
  - a) 0°;
  - b) 45°; and
  - c) 90°
- 5.6 For clarity, Table 1 shows a test matrix that defines the minimum testing requirement.

Test sequence / location	Test direction (degrees)	PTV for test number:										Mean PTV
		1	2	3	4	5	6	7	8	...	n	
1	0											
	45											
	90											
2	0											
	45											
	90											
3	0											
	45											
	90											
...	0											
	45											
	90											
X	0											
	45											
	90											

**Table 42: Example test matrix for supplied specimens**



## **6 Assessment of results**

- 6.1 For all test sequences / locations the mean Pendulum Test Values (PTV) measured in all directions shall exceed the minimum values required. These are detailed in the London Bus technical specification document available from TfL.

## **7 Test report**

- 7.1 The Test Service shall provide a comprehensive test report which contains UKAS test certificates for testing performed and presents the following:
- a) Test conditions;
  - b) Mean PTV;
  - c) The number of passengers transported by the vehicle at each assessment stage;
  - d) The amount of time that the flooring material type was in service for at each assessment stage.
  - e) Slip potential characterisation; and
  - f) Reference information:
    - i. Material type being assessed;
    - ii. The vehicle details on which the assessed material was installed.



# Attachment 33: Slip Protection

## Guidance Notes

---

### 1 Introduction

This document sets out the guidance notes related to flooring materials. These guidance notes are aimed at bus operators and manufacturers as a practical guide for implementation of the Bus Safety Standard.

These notes are for guidance only, and are not legally binding. In all circumstances, the guidance provided by a manufacturer of the bus or system shall take precedence, and these guidance notes are only for use in the absence of other information. These are not intended to be exhaustive, but to point the operators toward practical advice and questions to raise with manufacturers/suppliers.

### 2 Selection of buses/systems

Any bus that meets the TfL Bus Vehicle Specification.

Slip resistance testing should be carried out on all bus flooring materials in an as-new condition. The test protocol should be followed for the characterisation and acceptance of materials.

### 3 Training

Slip resistance testing should be carried out by a United Kingdom Accreditation Service (UKAS) accredited operator. Training may be provided by UKAS or another suitable training body if required.

Training for flooring installation should be provided by the flooring supplier.

### 4 Certification of flooring materials

Flooring material types<sup>25</sup> fitted to buses shall be supplied with a certification documentation pack that the slip resistance performance required by the 'London Bus Technical Specification' is met. The performance required is:

- At installation i.e. "as new", a PTV of least 36.
- After 100,000 persons have accessed the material, or after 6 months in service, whichever is sooner, a PTV of at least 40.
- Thereafter, for a period of 7 years from new, a PTV of at least 40, (based on an annual assessment).

---

<sup>25</sup> For the purposes of this document a flooring material type is considered as materials that share the same trade name and are constructed from using the same component parts and manufacturing processes.



Assessment of the skid resistance of the materials must be carried out in accordance with the test protocol. The assessment of materials must be carried by persons accredited by the United Kingdom Accreditation Service (UKAS) for the operation of the Portable Skid Resistance Tester (PSRT). This includes individuals working for the material manufacturer, bus manufacturer, bus operator or third party test house.

The certification of materials should, where appropriate take into account possible variations in material performance between manufactured batches. This may require the assessment of materials installed in a number of different vehicles.

For a material to be certified for use documentary evidence of the performance of flooring material types should be submitted in the form of (United Kingdom Accreditation Service) UKAS certificates which present as a minimum:

- The material type being assessed
- The vehicle details on which the assessed material was installed,
- The PTV of the material at each assessment stage,
- The number of passengers transported by the vehicle at each assessment stage,
- The amount of time that the flooring material type was in service for at each assessment stage.

This certification documentation pack should be based on one of the following options depending on whether the material is an existing or new material:

- Performance measured on in-service buses, for 'existing' materials
- Performance measured on in-service buses, for 'new' materials
- Performance measured in the laboratory, for 'existing' or 'new' materials

Each of these options is described in more detail below.

#### **4.1 Performance measured on in-service buses, for 'existing' materials**

Existing flooring materials may be certified by assessing the performance of those materials on currently in-service buses. For certification to be achieved the performance of the materials should be assessed on flooring materials meeting the temporal requirements specified in the specification document. Evidence for the certification of materials in this way could therefore be gathered quickly assuming that materials of the requisite ages could be identified.

#### **4.2 Performance measured on in-service buses, for 'new' materials**

If the option to certify new materials through laboratory testing is not invoked then new materials may also be assessed on in-service buses as per section 4.1. In this case the performance of the material, following its installation, must be reported at each assessment stage and the material replaced if the measurements of PTV at any of the assessments falls below the threshold stated in the specification. It would be expected that the floor material manufacturer would bear the costs of replacing the material.



#### 4.3 Performance measured in the laboratory, for 'new' or 'existing' materials

Ideally the assessment of materials will be carried out on in-service vehicles which meet the requirements of the specification. However, to encourage innovation, laboratory accelerated wear protocols may also be used to simulate the amount of footfall experienced by the flooring materials at the required intervals. If this option is invoked then additional evidence showing a strong correlation between the accelerated wear test, and in-service wear must be presented. This correlation should be demonstrated by showing the change in slip resistance as a result of wear testing with that of in-service wear on buses for typical bus flooring materials.

### 5 Replacement or repair of flooring materials

#### 5.1 Inspection

The bus flooring material shall be inspected using the standard intervals and protocols specific to the bus operating company. It is recommended however that inspections are carried out every 5 - 7 years'. The flooring material shall be visually inspected for any obvious defects following the standard inspection regimes used by the bus operating company and areas containing defects (as defined by the operating companies inspection regime) noted.

#### 5.2 Replacement

If defects are identified the affected section of the surface should be completely replaced with one characterised as providing a low slip potential and the appropriate wear resistance (as defined in the test protocol). A section of the surface is defined as an area of the surface which can be independently defined by its use. For example, a bus may consist of the following surfacing sections:

- Entrance ways,
- Aisles,
- Stairwells and landings,
- Seating areas,
- Disabled reservation areas,
- Etc...

If therefore a defect was identified in the aisle of a bus, then the entire width of flooring between the seats should be replaced.

Persons replacing bus flooring materials should be trained and competent to do so. The manufacturer's installation instructions should be followed precisely when replacing materials and, if available, training by the material manufacturer should be given. Particular care should be taken when welding material joints in order to protect the underlying materials.



### 5.3 Inspection and repair of the underlying materials

After the removal of defective material (and the surrounding area), the underlying materials should be inspected for damage and repaired as necessary. Conducting repairs at this stage will lengthen the life of the flooring materials and the bus.

## 6 Cleaning of bus flooring materials

The selection of bus flooring materials should take into account their cleaning and maintenance procedures. It is advised that materials with high levels of texture, or materials that are very coarse are not used. These materials are likely to provide high levels of PTV but will also be very hard to clean and could trap dirt and contaminants that could ultimately reduce their PTV characteristics.

Bus flooring materials should be cleaned regularly following the manufacturers recommended procedures. In cases where there are no manufacturer recommended procedures the following should be carried out:

1. Daily:
  - a. Vacuum the surface to remove dust and debris,
  - b. Use a mop to clean floor with clean water and a 2-5% neutral detergent solute as per manufacturer's instructions,
  - c. Rinse surface with a thoroughly cleaned mop and clean water to remove detergent residue.
  - d. Vacuum dry.
2. Once per month or after heavy soilage:
  - a. Vacuum the surface to remove dust and debris,
  - b. Scrub grease or oil spots only with a medium stiff bristled hand brush, rotocleaner or dingle brush machine with alkaline detergent
  - c. Use a mop to clean floor with clean water and a 2-5% neutral detergent solute as per manufacturer's instructions,
  - d. Rinse surface with copious amounts of clean water using a thoroughly cleaned mop to remove detergent residue.
  - e. Vacuum dry.
3. Never:
  - a. Use an electric scrubber with abrasive discs,
  - b. Use solvents,
  - c. Use industrial stain removers without first testing on a discrete area out of natural corridors,
  - d. Leave detergent residue on the floor,
  - e. Apply any surface treatment,
  - f. Use high pressure devices,
  - g. Place any form of rubber on the flooring.

## 7 Considerations of flooring colouring and patterns

It should be noted that the use of darker colours for bus floorings is preferential to lighter colours as dirt and detritus is less contrasting with darker colours and so is less visible.



There is a potential that flooring which is reflective or has reflective elements can look “sparkly” or “shiny”. There is the potential for some bus passengers to sub-consciously associate these features with flooring that is wet and therefore slippery. In these cases it is likely that these users will adjust their gait to compensate for the perceived lack of slip resistance. This is undesirable as it increases the risk to the passenger who may become off balanced or even fall as a result. With this in mind the use of materials with a matt hue are preferred to those with satin or gloss hues.

# Attachment 34: Occupant Friendly Interiors Assessment Protocol

---

## 1 Introduction

This document presents a protocol for:

- The inspection of a bus interior to identify potential injury hazards; and
- The assessment and rating of hazards identified.

The categories of potential hazards included in this protocol are:

- Handrails;
- Restraints – partitions and inadequately constrained seated passengers; and
- General/other hazards, such as sharp corners and protrusions.

### 1.1 Scope

This protocol applies to all new buses intended for service under contract to TfL that are passenger vehicles with a maximum mass exceeding 5 tonnes and a capacity exceeding 22 passengers. The passenger vehicles will be capable of carrying seated but unrestrained occupants and standing occupants. Such vehicles are categorised in the Consolidated Resolution on the Construction of Vehicles (R.E.3) as M<sub>3</sub>; Class I, Class II.

### 1.2 Purpose

The purpose of this assessment is to identify potential injury hazards present in the vehicle design. The protocol assesses and rates the identified hazards with the objective of encouraging safer vehicle designs, with minimal constraints for the vehicle designers. The protocol has been written to enable assessment using drawings or CAD models of the vehicle at the design stage.

## 2 Definitions

For the purpose of this Protocol:

- **3D:** Three dimensional, components in the x, y and z axes.
- **Approval Authority:** The Approval Authority is the body within TfL that certifies that a bus is approved for use in the TfL fleet and assigns its score under the bus safety standard for use in procurement processes.
- **Computer-Aided Design (CAD):** The use of computer systems to aid in the creation, modification, analysis, or optimization of a design.
- **Floor:** Vehicle floor where a passenger's feet will rest when seated or standing.
- **Head impact zone:** Height range in which a standing or seated passenger's is usually positioned.
- **'High occupancy / PRM' seats:** Seats with high occupancy rate and / or used by Persons with Reduced Mobility (PRM)—These seats include nominated priority / preferential seats, all seats on the main floor level and any seats immediately adjacent to a door. "Immediately adjacent to a door" means any seat in a row of seats near a door, even if only accessible via a step. Example of these seats behind the middle doors and wheelchair area with step to access are shown below.

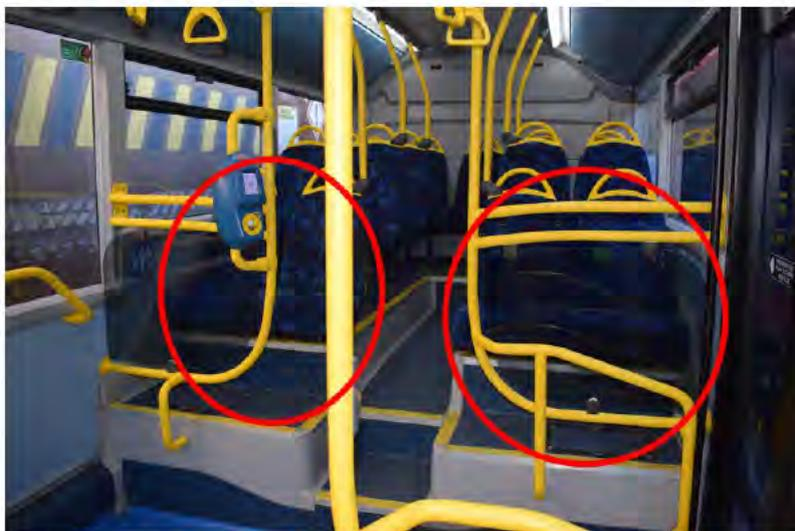

**Figure 44: Examples of seats with high occupancy rate immediately adjacent to a door and only accessible via a step.**

- **Partition-like structure:** Note that a partition like structure is defined as a continuous structure with apertures no greater than 50 mm and a lower edge not more than 100 mm above the floor where the passenger's feet rest.
- **Passenger trajectory plane (PTP):** vertical plane extending from the longitudinal centre of each box within the vertical handrail assessment space envelope to the vertical centreline of the primary handrail



- **Position line (PL):** Line representing a position from which a passenger could leave the confines of the box within the space envelope while being thrown towards the handrail
- **Primary handrail:** The handrail being assessed
- **Secondary handrail:** A handrail that can be used by a passenger to prevent a collision with the primary handrail.
- **Test Service:** The organisation undertaking the testing and certifying the results to the Approval Authority
- **Vehicle Manufacturer:** the business responsible for the manufacture of the bus being assessed.
- **Vehicle under Test (VuT):** means the vehicle assessed according to this protocol.

### 3 Test conditions

This protocol has been developed to be applied during the design of buses. This protocol shall be applied to CAD models or drawings of the VuT.

### 4 Test preparation

4.1 The following assessment envelopes/zones shall be defined by the Test Service in a universally compatible 3D CAD format e.g. .IGES or .STEP.

4.1.1 Standing passenger vertical handrail assessment space envelope. A plan view of the envelope is shown in Figure 45. The envelope shall extend from the ground plane of the VuT to a height of 1870mm. The ground plane of the space envelope shall follow the profile of the vehicle floor.

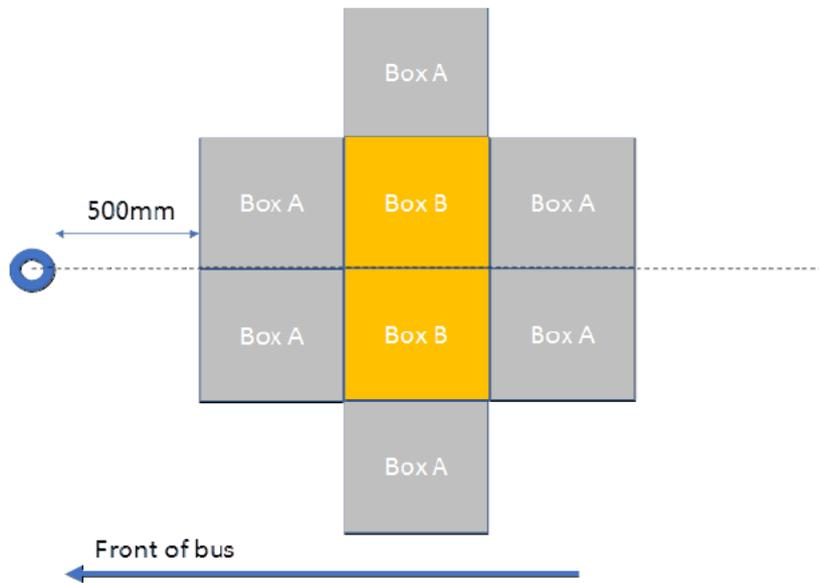

**Figure 45: Plan view of the vertical handrail assessment space envelope.**

4.1.2 Seated passenger handrail assessment zone. A side view of this zone relative to the seat being assessed is shown in Figure 46. The zone shall extend for the width of the seat being assessed.

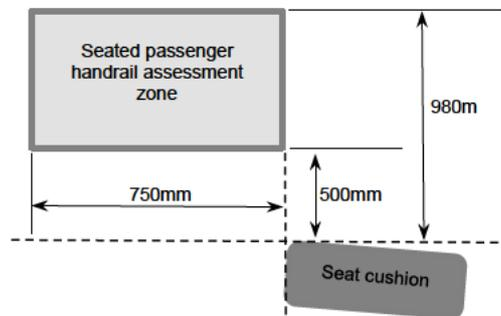

**Figure 46: Side view of seated passenger handrail assessment zone**

## 5 Test procedure

### 5.1 Standing passengers

5.1.1 This test only applies to the lower deck of the VuT on the basis that standing (for substantial periods) is prohibited on the upper deck.

#### 5.1.2 Handrails

5.1.2.1 This procedure considers vertical and horizontal handrails separately.

##### 5.1.2.2 Vertical handrails

5.1.2.2.1 A vertical handrail is a vertical structure which passes through two horizontal planes; 1310 mm and 1870 mm above the floor of the VuT at the location where the structure is installed. The diameter or width of the vertical structure in the vehicle's lateral plane shall be less than 45 mm. Attachments to the hand rails such as Oyster Card readers shall not be included in the definition of the structures diameter/width. All vertical handrails shall be identified.

5.1.2.2.2 Apply the Vertical Handrail Assessment Space Envelope to each of the vertical handrails identified. The centre of the handrail being assessed is the reference point for the template.

5.1.2.2.3 Identify the boxes in which a passenger is likely to stand by applying the following criteria:

5.1.2.2.4 Identify encroaching structures for each of the boxes within the space envelope.

5.1.2.2.5 There shall be at least space to fit a circle of 250 mm diameter touching the edge of the box that does not have any permanent structure encroaching within it for the box to be assessed that a passenger is likely to stand in it.

5.1.2.2.6 Determine if a passenger has an unobstructed path from a box to fall against the primary handrail. There shall be an unobstructed corridor at least 250 mm wide from the box to the primary handrail, defined using the following method:

- a) Along the forward edge of the box, draw three position lines (PL) each 250 mm long, one from each of two box corners to the edge's centre point, and one with the edge's centre point at its mid-point (see Figure 47 top picture lines in black, blue and red).
- b) For each PL, draw potential trajectory corridors by extending a vertical plane from each end of the position line to the edge of the handrail (so that the edge of the handrail is just touching the boundary of each corridor). The plane extending from the end of the PL farthest away from the primary handrail shall contact the handrail at the farthest point and the plane extending from the end of the PL nearest the handrail shall contact the handrail at its nearest point. Add two other planes parallel to each of these lines as illustrated in Figure 47 bottom picture. When complete this will give 6 corridors; two corridors for each PL.

5.1.2.2.7 If one or more of these corridors does not have a structure encroaching into it (at a height less than 1870 mm above bus floor level), it is deemed that a passenger has an unobstructed path to the primary handrail. Note that structures less than 300 mm from the primary handrail which do not shield it completely in the head impact zone (1420 mm to 1755 mm above bus floor) should not be counted as obstructions.

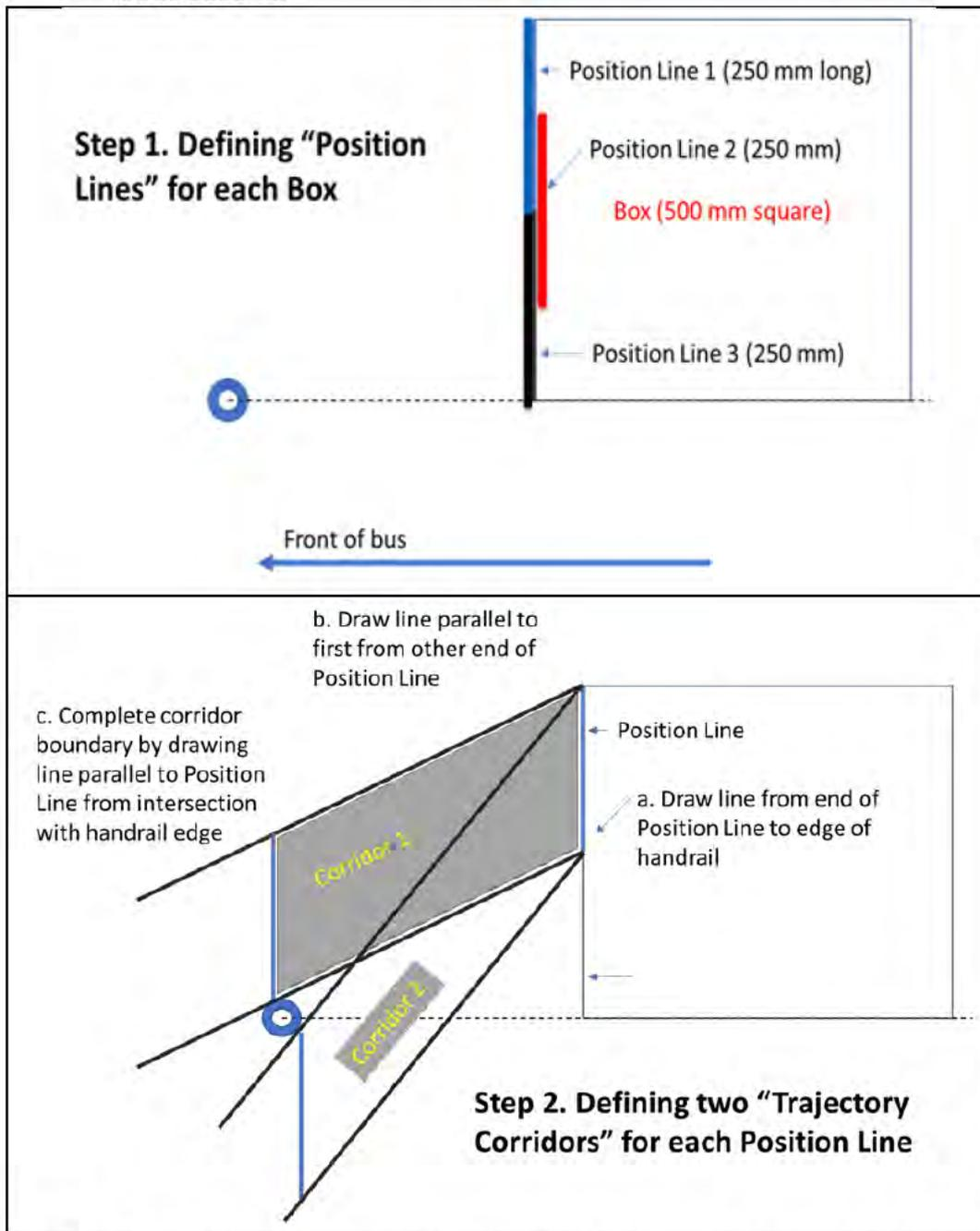
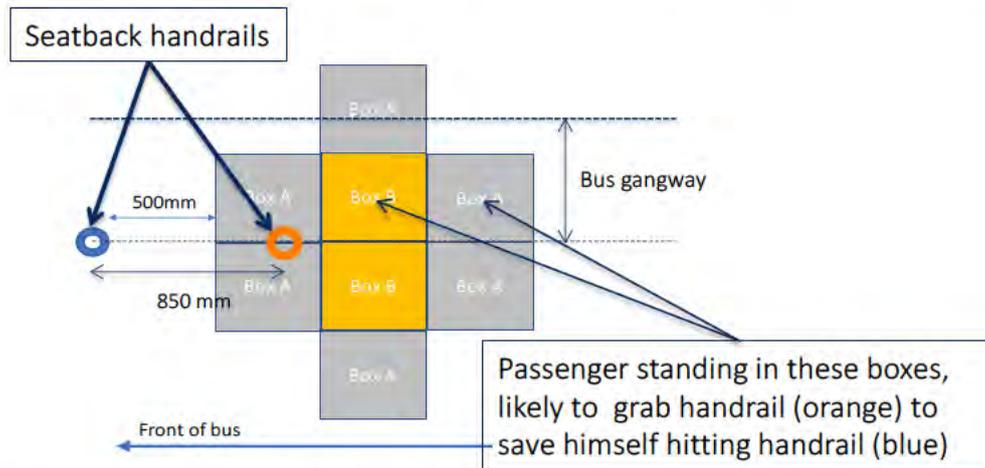

**Figure 47: Procedure to assess presence of unobstructed corridor to vertical handrail.**

5.1.2.2.8 Determine whether passengers have an opportunity to grab another handrail (secondary handrail) to prevent a collision with the primary handrail using the following method:

- a) The Passenger Trajectory Plane (PTP) shall be drawn from the centre of the front of each box to the centre of the primary handrail.
- b) A secondary handrail is defined as one positioned at least 500 mm longitudinally from the primary handrail and within a corridor extending 250 mm either side of the PTP.

5.1.2.2.9 Figure 48 shows an example of a seat back handrail (secondary handrail) positioned to give an opportunity to a passenger standing in the indicated boxes to prevent a collision with the primary handrail.



**Figure 48: Example of a seat back handrail positioned to give standing passenger opportunity to prevent a collision with the primary handrail.**

5.1.2.3 Horizontal handrails

5.1.2.3.10 All horizontal handrails shall be identified.

5.1.2.3.11 The height of the middle of each handrail above the bus floor shall be measured. The length of each handrail shall also be measured.

### 5.1.3 Restraint

- 5.1.3.1 Partitions that a passenger can stand behind shall be identified. These are defined as partitions which have a space extending at least 500 mm rearward across the width of the partition and to a height of 1870 mm.
- 5.1.3.2 The width of the partitions identified shall be measured.
- 5.1.3.3 For partitions with a width greater than 500 mm, the height of the partition above the VuT floor shall be measured:
- 5.1.3.4 Where the partition consists of more than one structure, the height of the highest structure shall be measured, e.g. the height of the seat backs for the partition illustrated in Figure 49.
- 5.1.3.5 Where the height of the partition above the floor varies, an average height shall be measured.

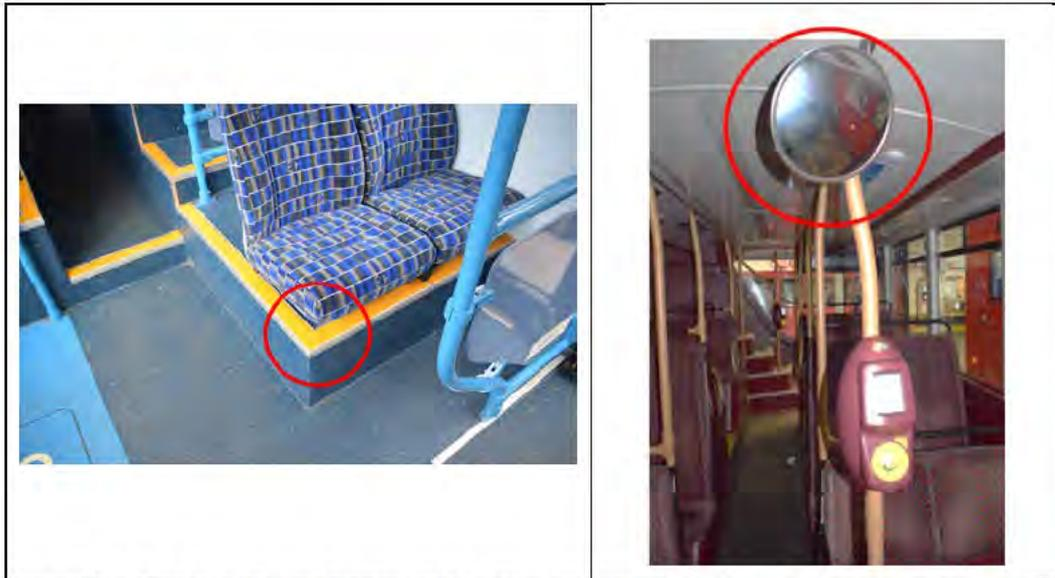

**Figure 49: Example of partition consisting of multiple structures**

### 5.1.4 General/other hazards

- 5.1.4.1 General hazards meeting the following criteria shall be identified:
  - a) Within the head impact zone – features with a shore hardness<sup>26</sup> rating greater than 60 with a radius less than 20mm.
  - b) Outside the head impact zone – features with a shore hardness rating greater than 60 with a radius less than 5mm.
- 5.1.4.2 Examples include step corners, corners of Passenger Information Systems (PIS) and ceiling mounted mirrors which are mounted within the head impact zone (Figure 50).
- 5.1.4.3 Items that move when impacted such as grab handles on straps attached to structures above 1870mm from the VuT floor shall not be identified as a hazard.

<sup>26</sup> Shore hardness is defined as a material's resistance to indentation when a static load is applied.



**Figure 50: Examples of general hazards for standing passengers, corner of step (left) and mirror in head impact zone (right).**

## 5.2 Seated passengers

5.2.1 The assessment shall be completed for both the lower and upper decks for forward facing seats.

### 5.2.2 Handrails

5.2.2.1 Identify handrails positioned within the seated passenger handrail assessment zone. Examples of handrails in this zone are shown in Figure 51. Handrails can be vertical or horizontal.

5.2.2.2 For each of the handrails identified, take the following measurements relative to the longitudinal centreline of the seat:

- a) Lateral (y-axis) distance from boundary (edge) of the handrail nearest to the seat centreline to the outer edge of the seat (d).
- b) The maximum width of the seat (w).

- 5.2.2.3 Identify whether or not the handrails assessed are associated with 'high occupancy / PRM' seats.

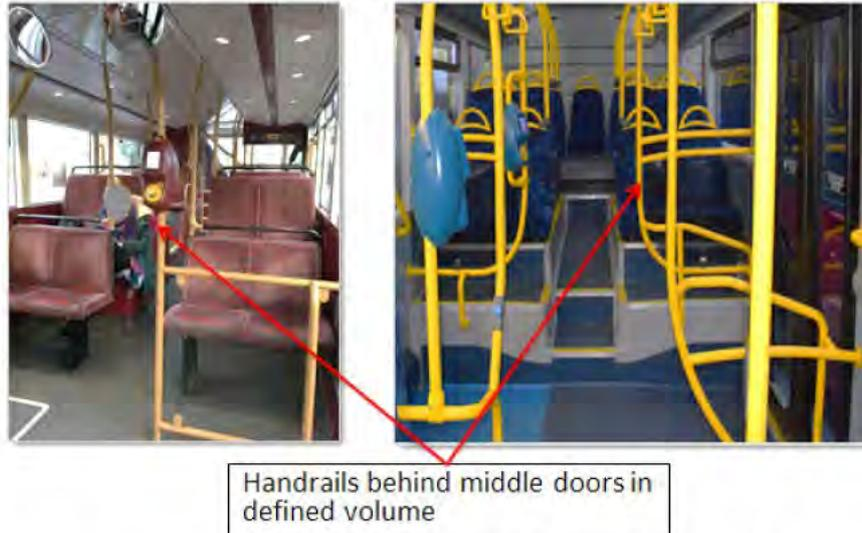
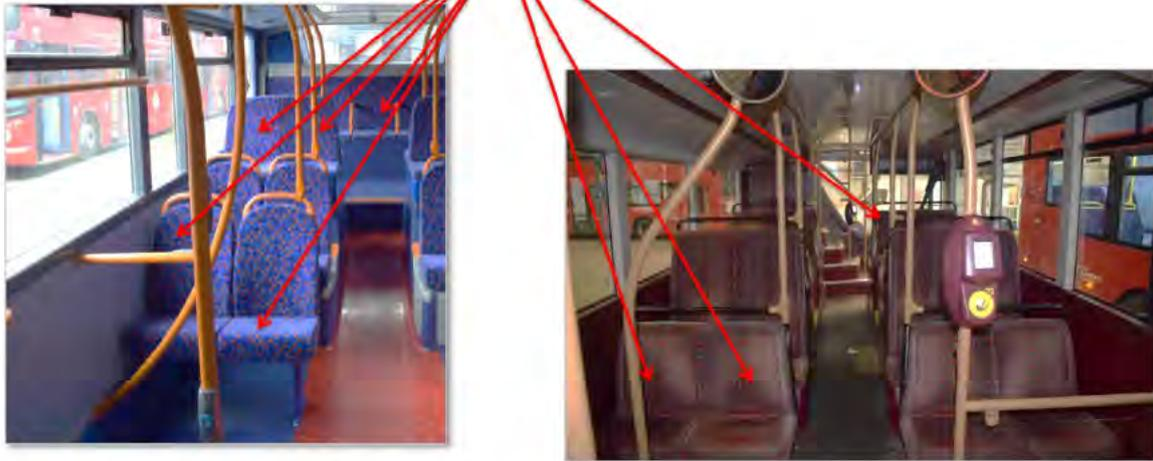

**Figure 51: Examples of handrails positioned behind middle doors in trajectory of seated occupant that shall be identified for further assessment.**

### 5.2.3 Restraint

- 5.2.3.1 For each seat, identify the level of restraint present using the following categories:
- No partition-like structure or other seats in front;
  - Bay seat arrangement; or
  - Some structure within a longitudinal distance of 1200 mm from seat back.
- 5.2.3.2 Where a seat has some structure in front of it, take the following measurements;
- The average height above the floor on which the passenger's feet rest for the seating position being assessed.
  - The maximum width of the seat ( $w$ ).
  - Define effective seat width ( $w_e$ ) as 75% of the maximum width positioned around the seat centreline. Project edges of effective seat width longitudinally forward to restraint structure. Measure effective seat width not covered by restraint structure ( $d$ ). See Figure 58.
- 5.2.3.3 Identify whether or not the restraints assessed are associated with PRM seats.

Inadequate restraint of passengers on some seats



**Figure 52: Examples of seats where there is inadequate restraint of seated passengers.**

#### 5.2.4 General hazards

5.2.4.1 Hazards meeting the following criteria shall be identified:

- a) Within the head impact zone – features with a shore hardness<sup>27</sup> rating greater than 60 with a radius less than 20mm.
- b) Outside the head impact zone – features with a shore hardness rating greater than 60 with a radius less than 5mm.

5.2.4.2 Examples include bolt heads, corners of Passenger Information Systems (PIS) and luggage racks which are mounted within the head impact zone (Figure 53). Note the full height glass partition in front of seated passenger is considered a hazard because it is likely to cause a head injury to a passenger if impacted and the risk of an impact is high.

<sup>27</sup> Shore hardness is defined as a material's resistance to indentation when a static load is applied.

<p>Protruding bolt heads in lower body impact area:                  Injury potential – low                  Risk of impact - low</p>	<p>Sharp corner on PIS in head impact area:                  Injury potential – high                  Risk of impact - low</p>
<p>Luggage rack rail behind rear facing seats in head impact zone:                  Injury potential – high                  Risk of impact - high</p>	<p>Full height glass partition in front of forward facing seats covering head impact zone:                  Injury potential – high                  Risk of impact - high</p>

**Figure 53: Examples of general hazards for seated passengers**



## 6 Assessment of results

### 6.1 Standing passengers

#### 6.1.1 Handrails

##### 6.1.1.1 Vertical

6.1.1.1.1 The boxes in the assessment template are scored as follows:

a) A score of 0.1 is given for each Box A that a passenger could stand in and which:

i. Has an unobstructed path to the handrail; and

ii. Presents no opportunity for the passenger to grab a secondary handrail.

iii. If any of these criteria are not met, the box is scored 0.

b) A score of 0.2 is given for each Box B that a passenger could stand in and which:

i. Has an unobstructed path to the handrail; and

ii. Presents no opportunity for the passenger to grab a secondary handrail.

iii. If any of these criteria are not met, the box is scored 0.

c) This results in maximum score of 1 for a handrail.

6.1.1.1.2 In the following situations this score is factored:

a) In the case that a handrail does not have a length of 560 mm between the lower boundary of 1310 mm and upper boundary of 1870 mm, e.g. it is not vertical. In this case the length of the handrail projected into the Y plane (i.e. plane transverse across the bus) should be measured and a factor of  $(\text{handrail length})/560$  applied.

b) In the case of handrails that curve away behind an obstruction (e.g. going further behind a row of seats), only those parts of the handrail within 250 mm of a longitudinal of the obstructing structure's outermost edge shall be considered within the zone. The length of handrail within the zone shall be measured and a factor of  $(\text{handrail length})/560$  applied.

##### 6.1.1.2 Horizontal

6.1.1.2.3 Using the data collected, each handrail shall be assessed as follows:

- a) For handrail height below 1130 mm score 0.
- b) For handrail height greater than 1130 mm and less than 1420 mm, linearly score between 0 and 1 by application of formula below:
- c)  $\text{Score} = (\text{'handrail height (mm)'} - 1130 \text{ mm}) / (1420 \text{ mm} - 1130 \text{ mm})$
- d) For handrail height greater than 1420 mm and less than 1755 mm, score 1
- e) For handrail height greater than 1755 mm and less than 1870 mm, linearly score between 1 and 0 by application of formula below:
- f)  $\text{Score} = (1870 \text{ mm} - \text{'handrail height (mm)'}) / (1870 \text{ mm} - 1755 \text{ mm})$
- g) For handrail height above 1870 mm score 0.



**Figure 54: Illustration of assessment for horizontal handrail based on its height above the bus floor.**

- 6.1.1.2.4 The score for each handrail shall be factored per 500 mm length by application of the formula below:

$$\text{Score} = (\text{'handrail score'}) * (\text{handrail length mm}) / 500 \text{ mm}$$

## 6.1.2 Restraint

- 6.1.2.1 The partition is scored based on its height and width as below:
- a) 'Partition height' less than 770 mm score 1
  - b) 'Partition height' greater than 770 mm and less than 1060 mm apply formula below:  

$$\text{Score} = (1060 \text{ mm} - \text{'Partition height (mm)'}) / 290 \text{ mm} * (\text{'Partition length (mm)'}) / 500 \text{ mm}$$
  - c) Partition height greater than 1060 mm score 0



**Figure 55: Illustration of assessment of restraint (partitions) for standing passengers.**

6.1.2.2 The score for each partition shall be factored per 500 mm length by application of the formula below:

$$\text{Score} = (\text{'Partition score'}) \times (\text{partition length mm}) / 500 \text{ mm}$$

### 6.1.3 General/other hazards

6.1.3.1 A score of 1 shall be given to any such hazard identified, or group of such hazards if they fall within the area of a 100 mm sided square area.

### 6.1.4 Weighting of hazards for standing passengers

6.1.4.1 The following weightings shall be applied to the scores for standing passengers:

- a) Handrails – multiply by 5
- b) Restraint – multiply by 4
- c) General / other hazards – multiply by 3

## 6.2 Seated passengers

### 6.2.1 Handrails

6.2.2 The handrail shall be scored as illustrated in Figure 56 as follows:

- If distance (d) from the edge of the rail closest to the seat centre to the outer edge of the seat in the vehicles y-axis is less than 100 mm, handrail scores 0;
- If distance (d) from the edge of the rail closest to the seat centre to the outer edge of the seat in the vehicles y-axis is greater than (half the seat width ( $w/2$ ) – 90 mm), handrail scores 1; and
- For distances in between those defined above, use the formula below to calculate a score between 0 and 1:

$$\text{Score} = (d - 100 \text{ mm}) / (w/2 - 190 \text{ mm})$$

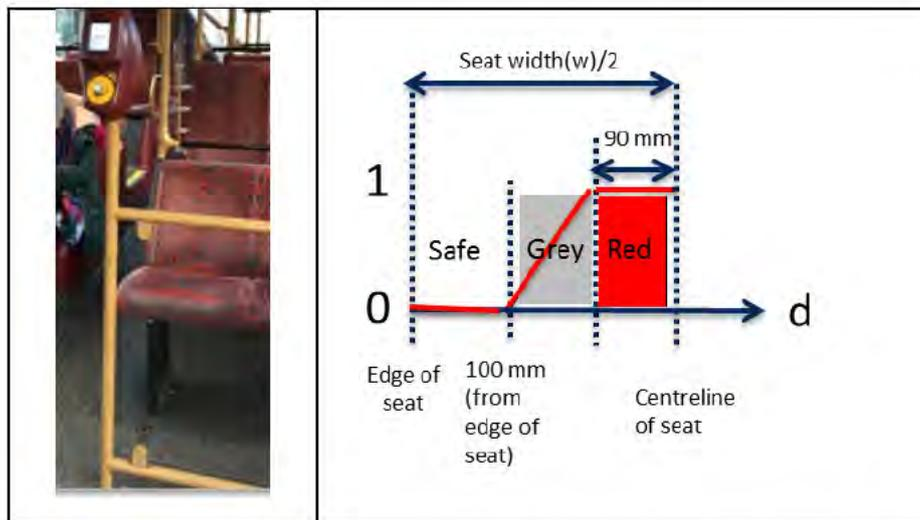

Figure 56: Procedure for assessment for handrails identified as a potential hazard for seated occupants.

### 6.2.3 Restraint

6.2.3.1 The seats identified shall be assessed as follows:

- a) Seats with no or little structure in front of them (i.e. no partition like structure or other seats) shall be scored 1;
- b) Bay seat arrangements shall be scored 0.75;
- c) Seats with some structure (partition line structure or other seats) in front of them shall be assessed as follows;
  - i. The proportion of the effective seat width projected forward not covered by the restraint structure shall be calculated using the formula below (see Figure 58):
  - ii. Proportion not covered ( $P_{we}$ ) = 'distance not covered in mm' (d) / 'Effective seat width mm' ( $w_e$ )
  - iii. If the height of the structure is 800 mm or greater, score ( $1 * P_{we}$ ).
  - iv. If the height of the structure is 700 mm or less, the structure's height is in red zone, score 1.
  - v. If height of structure is between 700 mm and 800 mm, the formula below shall be applied to calculate score between 0 and 1:

$$\text{Score} = (P_{we}) + (800 \text{ mm} - \text{Structure's height mm}) / 100 \text{ mm}$$

Note: Scores calculated to be greater than 1 should be capped at 1.

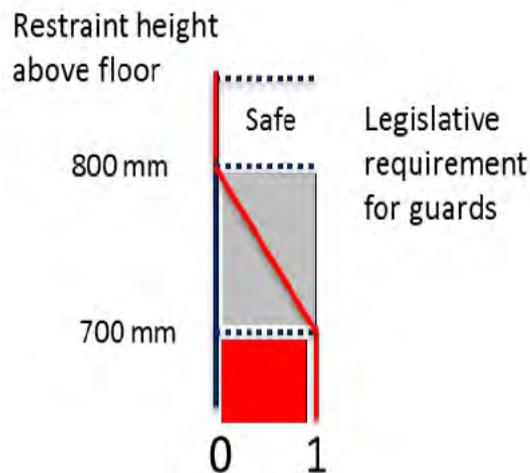

**Figure 57: Illustration of safe, grey and red zones for height of restraint assessment.**

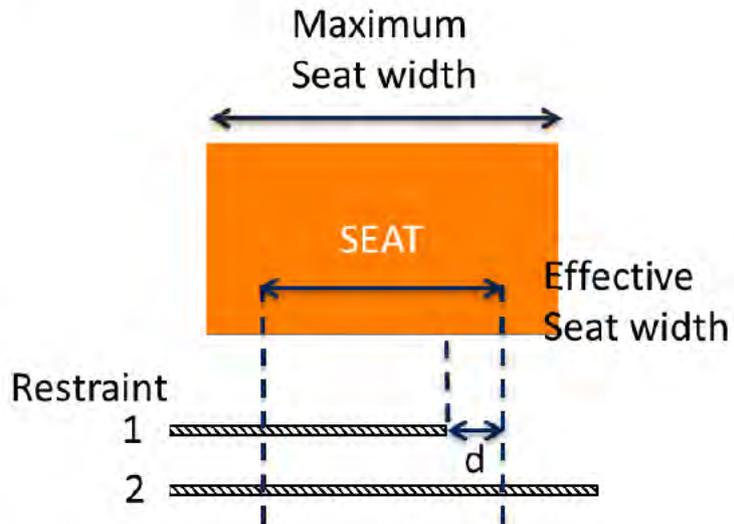

**Figure 58: Illustration of effective seat width not covered by restraint structure, distance  $d$  for Restraint No 1, all covered by Restraint No 2, i.e.  $d = 0$ .**



#### 6.2.4 **General/other hazards**

- 6.2.4.1 For each seat position, an assessment of the injury potential and risk of impact shall be made for the hazards identified and a score of up to 1.0 given, in accordance with the following criteria:
- a) Injury potential:
    - i. For head impact categorise as high
    - ii. For impact of other body regions categorise as low
  - b) Risk of impact:
    - iii. For small sized hazard such as single bolt head (or single group of hazards within 100 mm of each other) categorise as low
    - iv. For hazard covering area likely to be impacted by body region e.g. multiple small sized hazards (e.g. > 4) or single hazard covering area in good alignment with head trajectory categorise as high
  - c) Score:
    - v. Injury potential low, risk of impact low; score 0.3
    - vi. Injury potential high, risk of impact low and vice versa; score 0.6
    - vii. Injury potential high, risk of impact high; score 1.0

#### 6.2.5 **Weighting of hazards for seated passengers**

- 6.2.5.1 The following weightings shall be applied to hazards not associated with 'high occupancy / PRM' seats:
- a) Handrails – multiply by 5
  - b) Restraint – multiply by 4
  - c) General / other hazards – multiply by 4
- 6.2.5.2 For 'High occupancy / PRM' seats, the following weighting shall be applied:
- a) Handrails – multiply by 10
  - b) Restraint – multiply by 8
  - c) General / other hazards – multiply by 8



## **7 Assessment template**

- 7.1 Each of the scores shall be entered into an assessment template made up of the tables shown in Appendix 1: Assessment Template.
- 7.2 The Total Actual Score is the sum of the weighted score for each assessment section, which are highlighted yellow. A separate value shall be calculated for the lower saloon, the upper saloon and the vehicle as a whole.

## **8 Normalising the score**

- 8.1 The basic score system above produces a higher score the greater the number of hazards identified and, theoretically, there is no upper limit to the score. Ideally the score would be zero with no identified hazards.
- 8.2 In order to incorporate the interiors score within an overall bus safety score, it is necessary to 'normalise' this score to a value between 0% and 100%, where 0% represents the worst vehicles and 100% the best.
- 8.3 In order to do this a maximum points ceiling shall be set at 120 points for the lower saloon and 12 points for the upper saloon. Thus the overall maximum points is 120 points for a single deck vehicle and 132 points for a double deck vehicle.
- 8.4 A Total Limited Score shall be defined for the lower saloon, the upper saloon and the vehicle as a whole and shall be the lesser of the Total Actual Score and the Maximum score.
- 8.5 The Normalised Score for lower saloon, upper saloon and whole vehicle shall be calculated according to the formula  $1 - (\text{Total Limited Score} / \text{Maximum Score})$  and expressed as a percentage.

## **9 Test report**

- 9.1 The Test Service shall provide a comprehensive test report that will be made available to the Approval Authority. The test report shall consist of three distinct sections:
- a) Confirmation of protocol compliance; and
  - b) Reference information.
- 9.2 To confirm protocol compliance, the Test Service shall include in the report the completed Occupant Friendly Interiors Assessment worksheet
- 9.3 The reference information required includes as a minimum:
- a) Vehicle make;
  - b) Vehicle model;
  - c) Vehicle model variant;
  - d) Details of the Test Service; and
  - e) Test date(s).



# 10 Appendix 1: Assessment Template

Note: Values entered in the tables below are fictional values for illustrative purposes only.

Section 1. Standing Passengers										Weighted	
Vertical (& near) Handrails	Length factor	Box A's (Max 0.1 each)						Box B's (Max 0.2 each)		Total	15.04
		Score	Score	Score	Score	Score	Score	Score	Score		
Handrail 1	1.00	0.10	0.10					0.20		0.40	
Handrail 2	1.00	0.10								0.10	
Handrail 3	1.16	0.10	0.10	0.10				0.20		0.58	
Handrail 4	0.00									0.00	
Handrail 5	1.00	0.10	0.10	0.09	0.09			0.20	0.20	0.78	
Handrail 6	0.86	0.10	0.10					0.20		0.34	
Handrail 7	0.86	0.10	0.10					0.20		0.34	
Handrail 8	0.86	0.10	0.10					0.20		0.34	
Handrail 9	0.71	0.10								0.07	
Handrail 10	0.45	0.10								0.05	
Handrail 11										0.00	
Handrail 12										0.00	
Handrail 13										0.00	
Handrail 14										0.00	
Handrail 15										0.00	
Handrail 16										0.00	
Handrail 17										0.00	
Handrails 18 or more										0.00	
For handrail curved in bus Y plane: Length Factor = (Length in mm between 1310 mm and 1870 mm from floor)/560; For straight handrails Length Factor = 1 0 For handrail that curves behind obstruction: Length Factor = (Length in mm between 1310 mm and 1870 mm from floor AND < 250 mm from edge of obstruction)/560											
Horizontal (& near) Handrails	Length Factor	Red/Grey/Safe Zone factor							Total	13.00	
Handrail 1	2.60	1.00								2.60	
Handrail 2										0.00	
Handrail 3										0.00	
Handrail 4										0.00	
Handrail 5										0.00	
Handrail 6 or more										0.00	
Length Factor = (Length in mm)/500 Red Zone Factor (F rail > 1420 mm from floor AND rail < 1755 mm) = 1 Grey Zone Factor (if rail between 1755 mm and 1870 mm from floor) = (1870 - 'height of rail from floor in mm')/115 Grey Zone Factor (if rail between 1130 mm and 1420 mm from floor) = ('height of rail from floor in mm' - 1130)/290 Safe Zone Factor (if rail > 1870 mm from floor OR < 1130 mm from floor) = 0											
Restraint	Length factor	Red/Grey/Safe Zone factor							Total	0.00	
Restraint 1	0.00	1.00								0.00	
Restraint 2										0.00	
Restraint 3										0.00	
Restraint 4										0.00	
Restraint 5										0.00	
Restraint 6 or more										0.00	
Length Factor = (Length in mm)/500 Red Zone Factor (F partition height < 770 mm from floor) = 1 Grey Zone Factor (if partition height between 770 mm and 1060 mm from floor) = (1060 - 'partition height from floor in mm')/290 Safe Zone Factor (if partition height > 1060 mm from floor) = 0											
General/Other Hazards	Score (0 or 1)							Total	9.00		
Hazard 1	1.00								1.00		
Hazard 2	1.00								1.00		
Hazard 3	1.00								1.00		
Hazard 4									0.00		
Hazard 5									0.00		
Hazard 6									0.00		
Hazard 7									0.00		
Hazard 8									0.00		
Hazard 9									0.00		
Hazard 10 or more									0.00		
Section 2. Seated Passengers (Lower Deck)											
Handrails	Red/Grey/Safe Zone Factor	No. identical (seats)	PRM seat? (Y/N)							Total	40.71
Handrail 1	1.00	1.00	Y								2.00
Handrail 2	0.86	2.00	Y								3.43
Handrail 3	0.86	2.00	N								1.71
Handrail 4	1.00	1.00	N								1.00
Handrail 5											0.00
Handrail 6											0.00
Handrail 7											0.00
Handrail 8											0.00
Handrail 9											0.00
Handrail 10											0.00
Handrail 11											0.00
Handrail 12 or more											0.00
Red Zone Factor (F distance edge of rail nearest to seat centreline to outer edge of seat in mm (d) > ('half seat width in mm' (w/2) - 90) = 1 Safe Zone Factor (F distance edge of rail nearest to seat centreline to outer edge of seat in mm (d) < 100) = 0 Grey Zone Factor (F distance edge of rail nearest to seat centreline to outer edge of seat in mm (d) > 100 AND < ('half seat width in mm' (w/2) - 90) = (d - 100)/(w/2 - 190)											



Restraint Hazards	Red/Grey/Safe Zone Factor	Proportion not covered factor	PRM seat? (Y/N)	Total
Restraint 1	1.00	1.00	N	1.00
Restraint 2	0.75	1.00	N	1.00
Restraint 3	0.75	1.00	N	1.00
Restraint 4				0.00
Restraint 5				0.00
Restraint 6 or more				0.00
Score 1 if seat facing directly into aisle or other empty space. Score 0.75 for pair of front-facing bay seats Red zone factor (F height of restraint above floor in mm (h) < 700 mm) = 1 Safe zone factor (F height of restraint above floor in mm (h) > 800 mm) = 0 Grey zone factor (F height of restraint above floor in mm (h) > 700 mm and < 800 mm) = (800 - h)/100 Proportion (of effective seat width) not covered factor (Pwe) = 'distance not covered in mm' (d) / 'Effective seat width mm' (we) For safe zone score add Pwe For grey zone score add Pwe and if score > 1, cap score of 1				
General/Other Hazards	Score (0.3, 0.6 or 1)	No. identical (seats)	PRM seat? (Y/N)	Total
Hazard 1				0.00
Hazard 2				0.00
Hazard 3				0.00
Hazard 4				0.00
Hazard 5				0.00
Hazard 6				0.00
Hazard 7				0.00
Hazard 8 or more				0.00
Injury potential: Head impact high; Other body regions low Risk of impact: i. For small sized hazard such as single bolt head (or single group of hazards within 100 mm of each other) categorise as low; ii. For hazard covering area likely to be impacted by body region e.g. multiple small sized hazards (e.g. > 4) or single hazard covering area in good alignment with head trajectory categorise as high Score: i. Injury potential low, risk of impact low; score 0.3 ii. Injury potential high, risk of impact low and vice versa; score 0.6 iii. Injury potential high, risk of impact high; score 1.0				
Section 3. Seated Passengers (Upper Deck)				
Handrails	Red/Grey Zone Factor	No. identical (seats)	PRM seat? (Y/N)	Total
Handrail 1	1.00	8.00	N	8.00
Handrail 2	1.00	1.00	N	1.00
Handrail 3			N	0.00
Handrail 4			N	0.00
Handrail 5			N	0.00
Handrail 6			N	0.00
Handrail 7			N	0.00
Handrail 8			N	0.00
Handrail 9			N	0.00
Handrail 10			N	0.00
Handrail 11			N	0.00
Handrail 12 or more			N	0.00
Red Zone Factor (F distance edge of rail nearest to seat centreline to outer edge of seat in mm (d) > ('half seat width in mm' (w/2) - 90) = 1 Safe Zone Factor (F distance edge of rail nearest to seat centreline to outer edge of seat in mm (d) < 100) = 0 Grey Zone Factor (F distance edge of rail nearest to seat centreline to outer edge of seat in mm (d) > 100 AND < ('half seat width in mm' (w/2) - 90) = (d - 100)/(w/2 - 190)				
Restraint Hazards	Restraint height factor	Seat width factor	PRM seat? (Y/N)	Total
Restraint 1	1.00	1.00	N	1.00
Restraint 2			N	0.00
Restraint 3			N	0.00
Restraint 4			N	0.00
Restraint 5			N	0.00
Restraint 6 or more			N	0.00
Score 1 if seat facing directly into aisle or other empty space. Score 0.75 for pair of front-facing bay seats Red zone factor (F height of restraint above floor in mm (h) < 700 mm) = 1 Safe zone factor (F height of restraint above floor in mm (h) > 800 mm) = 0 Grey zone factor (F height of restraint above floor in mm (h) > 700 mm and < 800 mm) = (800 - h)/100 Proportion (of effective seat width) not covered factor (Pwe) = 'distance not covered in mm' (d) / 'Effective seat width mm' (we) For safe zone score add Pwe For grey zone score add Pwe and if score > 1, cap score of 1				
General/Other Hazards	Score (0.3, 0.6 or 1)	No. identical (seats)	PRM seat? (Y/N)	Total
Hazard 1			N	0.00
Hazard 2			N	0.00
Hazard 3			N	0.00
Hazard 4			N	0.00
Hazard 5			N	0.00
Hazard 6			N	0.00
Hazard 7			N	0.00
Hazard 8			N	0.00
Hazard 9			N	0.00
Hazard 10 or more			N	0.00
Injury potential: Head impact high; Other body regions low Risk of impact: i. For small sized hazard such as single bolt head (or single group of hazards within 100 mm of each other) categorise as low; ii. For hazard covering area likely to be impacted by body region e.g. multiple small sized hazards (e.g. > 4) or single hazard covering area in good alignment with head trajectory categorise as high Score: i. Injury potential low, risk of impact low; score 0.3 ii. Injury potential high, risk of impact low and vice versa; score 0.6 iii. Injury potential high, risk of impact high; score 1.0				



# Attachment 35: Occupant Friendly Interiors Guidance Notes

---

## 1 Introduction

This document sets out the guidance notes related to occupant friendly interiors and the bus interior safety assessment protocol. These guidance notes are aimed at bus operators and manufacturers as a practical guide for implementation of the Bus Safety Standard.

These notes are for guidance only, and are not legally binding. In all circumstances, the guidance provided by a manufacturer of the bus or system shall take precedence, and these guidance notes are only for use in the absence of other information. These are not intended to be exhaustive, but to point the operators toward practical advice and questions to raise with manufacturers/suppliers.

## 2 Explanation of approach for assessment protocol

The bus interior safety assessment protocol involves the identification and assessment of bus interior potential hazards (i.e. features that have injury causing potential) present in three categories; handrail, restraint and general (for standing and seated passengers), as shown diagrammatically in Figure 59. The assessment gives points for each potential hazard identified. More points are given for hazards which have greater injury causing potential and greater exposure (e.g. hazards associated with seats that are likely to be used more often). The aim is to encourage manufacturers to have as few potential hazards as possible and therefore score the minimum number of points, i.e. a lower score correlates with a better assessment.

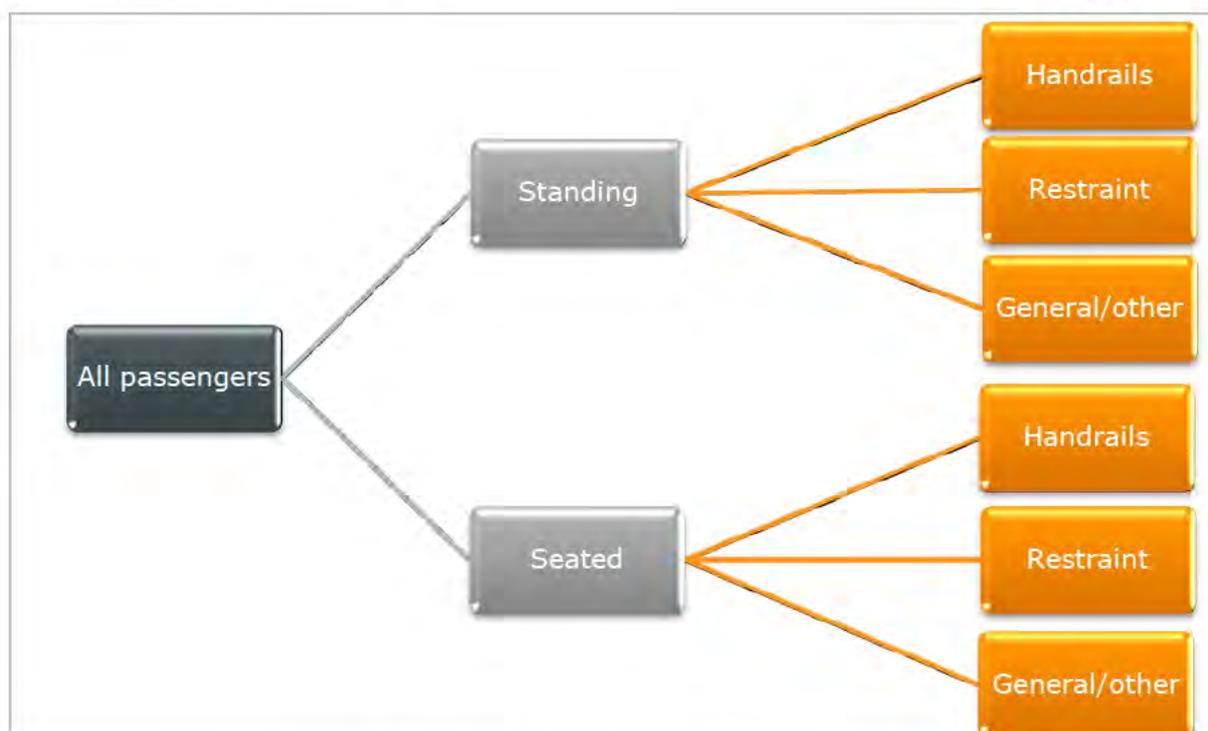

**Figure 59. Visual inspection hazard categories**

The approach to perform an inspection and assessment is as follows:

- Identify and count potential hazards in each category for standing and seated passengers.
- Scale individual potential hazards according to passenger exposure. This step is also used to avoid discontinuities in the assessment system. To help understanding of this step, an example of the scaling for horizontal handrails (for standing passengers) is given in *italics* on the page below.
- Further weight the points for each potential hazard identified in each of the six categories (handrail, restraint and general for standing and seated passengers) and sum them to give overall point scores for the lower deck and upper deck (if appropriate). Weightings are applied to reflect the following:
  - (a) The injury potential of the hazard, e.g. if the hazard is likely to cause a head injury as opposed to a lower limb injury, a higher weighting is given.
  - (b) Exposure of the hazard, e.g. if the hazard is in an area of the bus with a higher occupancy rate, a higher weighting is given. Also, additional weighting is applied to hazards to which persons with reduced mobility (PRM) are likely to be exposed. This is because, generally, PRM have slower reaction times and are less tolerant to injury, which can increase their likelihood of impacting a hazard and being injured.

Horizontal handrails can be positioned where they may be hit by a standing passenger's head, when that passenger falls. The likelihood of this occurring depends on the position height of the rail. The more the rail is in alignment with a passenger's head, the more likely it is that it will be hit. To account for this and to avoid discontinuities, a sliding scale scoring system has been developed that gives a

score ranging from 0 to 1. This results in red, grey and safe zones as illustrated in the left hand side of Figure 60 below.

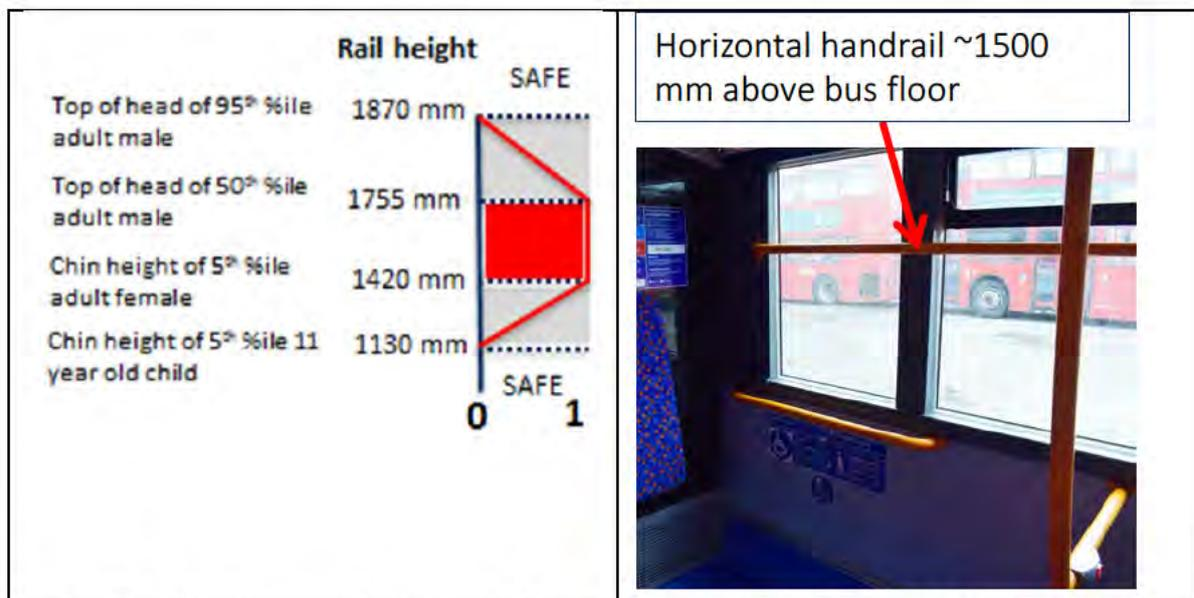

**Figure 60: Illustration of concept. Top rail in picture is about 1500 mm above the bus floor and in the red zone (and scores 1) whereas the bottom rail is about 1000 mm above the bus floor and in the safe zone (and scores 0). Grey zones, in which the score is scaled linearly from 1 to zero depending on the height of the rail above the bus floor, are positioned between the red and safe zones.**

- The red zone is positioned between 1420 mm (height of chin of 5<sup>th</sup> percentile female) and 1755 mm (height of top of head of 50<sup>th</sup> percentile male). The head height of a substantial proportion of the population will be in this zone. Therefore a passenger is likely to hit their head on a rail positioned at this height. Hence, a score of 1 (per unit length) is given for a horizontal rail positioned within this zone. The unit length chosen was 500 mm on the basis that this is approximately the space taken up by one passenger stood or leaning against the side of the bus.
- The grey zones are positioned above and below the red zone. The top grey zone is positioned between 1755 mm (height of top of head of 50<sup>th</sup> percentile male) and 1870 mm (height of top of head of 95<sup>th</sup> percentile male). The head height of a large proportion of the population will be in this zone, with the proportion reducing to about 5 % as the height becomes closer to 1870 mm. Hence, a score linearly reducing from 1 to 0 (per unit length) is given for a rail positioned in this zone depending on the precise height of its centre. For example a rail with a top edge height of 1800 mm would be scored  $(1870 - 1800)/(1870 - 1755) = 0.61$  per unit length. The bottom grey zone is positioned between 1420 mm (height of chin of 5<sup>th</sup> percentile female) and 1130 mm (height of chin of 5<sup>th</sup> percentile 11 year old child). A similar argument applies and approach is taken for this zone as for the top grey zone.
- The safe zones are positioned above and below the grey zones. These zones are above 1870 mm (top safe zone) and below 1130 mm (bottom



safe zone). The head height of a small proportion of the population will be in these zones. Therefore a score of zero is given for rails positioned in these zones.

*Note: It can be seen that if a manufacturer decides to change the height of a horizontal handrail by a small amount, say 10 mm, then the score will only change a small amount to reflect this, i.e. there are no discontinuities in the assessment system with the sliding scale approach.*

### **3 Selection of buses/systems**

A bus interior safety assessment should be carried out on each different bus model and variant in a 'ready for service' condition, i.e. with additional items such as TfL iBUS modules fitted. This assessment should be carried out by a TfL nominated supplier.

It is expected that manufacturers will wish to achieve given interior safety assessment values as targets for new bus designs. Therefore, they will need to be able to estimate the assessment values for potential designs throughout the design process. For these reasons, the assessment protocol has been kept as simple as possible (it is based mainly on simple measurements), so that it should be easily possible to perform an assessment based on 3D CAD information.

### **4 Training**

Training and consultancy related to carrying out a bus interior assessment should be provided by a TfL nominated supplier.

### **5 Retro-fitment of additional items**

Following the assessment of a bus model / variant in a 'service ready' condition by a TfL nominated supplier, additional items which alter the assessment should not be fitted to the bus (e.g. by operators). If it is necessary to fit items, which may alter the assessment, TfL should be consulted.



# Attachment 36: Bus Impact Test

## Standard Assessment Protocol

---

### 1 Introduction

This document presents a procedure, hereon referred to as the Bus VRU Impact Test Standard (BITS), for objectively measuring the impact protection provided by the front end of a bus in the event of a collision with a vulnerable road user (VRU); in particular, when striking their head.

#### 1.1 Scope

This protocol applies to all new buses intended for service under contract to TfL that are passenger vehicles with a maximum mass exceeding 5 tonnes and a capacity exceeding 22 passengers. The passenger vehicles will be capable of carrying seated but unrestrained occupants and standing occupants. Such vehicles are categorised in the Consolidated Resolution on the Construction of Vehicles (R.E.3) as M<sub>3</sub>; Class I, Class II.

#### 1.2 Purpose

The purpose of this test and assessment protocol is to bring about an improvement in the construction of certain components of the front end of buses which have been identified as causing injury when in collision with a pedestrian's, or other vulnerable road user's, head.

The vehicles that will be tested under the Bus VRU Impact Test Standard (BITS) are representative of the majority of buses in circulation in the urban environment, where there is a significant potential for bus collisions with pedestrians and other vulnerable road users.



## 2 Normative References

The following normative documents, in whole or in part, are referenced in this document and are indispensable for its application. For dated references, only the edition cited applies. For undated references, the latest edition of the referenced document (including any amendments) applies.

- Directive 2007/46/EC of the European Parliament and of the Council establishing a framework for the approval of motor vehicles and their trailers, and of systems, components and separate technical units intended for such vehicles.
- International Standard ISO 384:1976. Road vehicles – Measurement of impact velocity in collision tests
- International Standard ISO 6487:2015. Road vehicles – Measurement techniques in impact tests – Instrumentation
- Regulation (EU) 2018/858 of the European Parliament and of the Council of 30<sup>th</sup> May 2018 on the approval and market surveillance of motor vehicles and their trailers, and of systems, components and separate technical units intended for such vehicles, amending Regulations (EC) No 715/2007 and (EC) No 595/2009 and repealing Directive 2007/46/EC.
- UN Regulation No. 107. Uniform provisions concerning the approval of category M<sub>2</sub> or M<sub>3</sub> vehicles with regard to their general construction.
- UN Regulation No. 127. Uniform provisions concerning the approval of motor vehicles with regard to their pedestrian safety performance.

### 3 Definitions

For the purpose of this protocol:

- 3.1 **Adult headform** - is the test tool used to represent the head of an adult in these impact tests. It is identical to those used in UN Regulation No. 127 and GTR No. 9 and is defined specifically in Test impactor specifications.
- 3.2 **Adult headform test area** - is an area on the outer surfaces of the front structure. The area is bounded:
  - 3.3 At the lower edge, by a Wrap Around Distance (WAD) of [1,500]mm from the ground reference plane (with the vehicle at its nominal ride attitude) (WAD1500);
  - 3.4 At the upper edge, by a WAD of [1,850] mm from the ground reference plane (with the vehicle at its minimum ride attitude) (WAD1850); and
  - 3.5 At each side, by a line 82.5 mm inside the side reference line. The distance of 82.5 mm is to be set with a flexible tape held tautly parallel to the horizontal plane of the vehicle and along the outer surface of the vehicle.
- 3.6 **A-pillar** - means the foremost and outermost roof support extending from the chassis to the roof of the vehicle.
- 3.7 **Bus front end** - means all outer structures of the front end of the vehicle exposed to a potential collision with a VRU. It may therefore include, but is not limited to, the bumper, the bonnet or grille, scuttle, wiper spindles, lower windscreen frame, the windscreen, the windscreen header and the A-pillars.
- 3.8 **Child headform** - is the test tool used to represent the head of a child in these impact tests. It is identical to those used in UN Regulation No. 127 and GTR No. 9 and is defined specifically in Test impactor specifications.
- 3.9 **Child headform test area** - is an area on the outer surfaces of the front structure. The area is bounded:
  - 3.10 At the lower edge, by a WAD of [1,115] mm from the ground reference plane (with the vehicle at its maximum ride attitude) (WAD1115);
  - 3.11 At the upper edge, by a WAD [1,500] mm from the ground reference plane (with the vehicle at its nominal ride attitude) (WAD1500); and
  - 3.12 At each side, by a line 82.5 mm inside the side reference line. The distance of 82.5 mm is to be set with a flexible tape held tautly parallel to the horizontal plane of the vehicle and along the outer surface of the vehicle.
- 3.13 **Driver mass** - means the nominal mass of a driver that shall be [68] kg.
- 3.14 **Ground reference plane** - means a horizontal plane, either real or imaginary, that passes through the lowest points of contact for all tyres of

a vehicle. If the vehicle is resting on the ground, then the ground level and the ground reference plane are one and the same. If the vehicle is raised off the ground such as to allow extra clearance, then the ground reference plane is above ground level; and if the vehicle (perhaps a test sample) is lower than it would be in running order, then the ground reference plane is below the ground level.

3.15 **Head Injury Criterion (HIC<sub>15</sub>)** - means the calculated result of accelerometer time histories over a maximum recording period of 15 milliseconds using the following formula:

$$3.16 \quad \text{HIC}_{15} = \left[ \frac{1}{t_2 - t_1} \int_{t_1}^{t_2} a \, dt \right]^{2.5} (t_2 - t_1)$$

3.17 Where:

- (a) "a" is the resultant acceleration measured in units of gravity "g" (1 g = 9.81 m/s<sup>2</sup>);
- (b) "t1" and "t2" are the two time instants (expressed in seconds) during the impact, defining an interval between the beginning and the end of the recording period for which the value of HIC is a maximum (t<sub>2</sub> - t<sub>1</sub> ≤ 15 ms).

3.18 **Mass in running order** - means the nominal mass of a vehicle as determined by the sum of the unladen vehicle mass and driver's mass.

3.19 **Measuring point** - The measuring point may also be referred to as "test point" or "impact point".

3.19.1 In all cases, the result of the test shall be attributed to this point, independent of where first contact occurs.

3.19.2 "Measuring point" for the headform test means a point on the vehicle's outer surface selected for assessment. The measuring point is where the headform's profile contacts the vehicle's outer surface cross section in a vertical longitudinal plane through the centre of gravity of the headform (see Figure 61). It will not be coincident with the centre of the headform for contacts with an inclined surface.

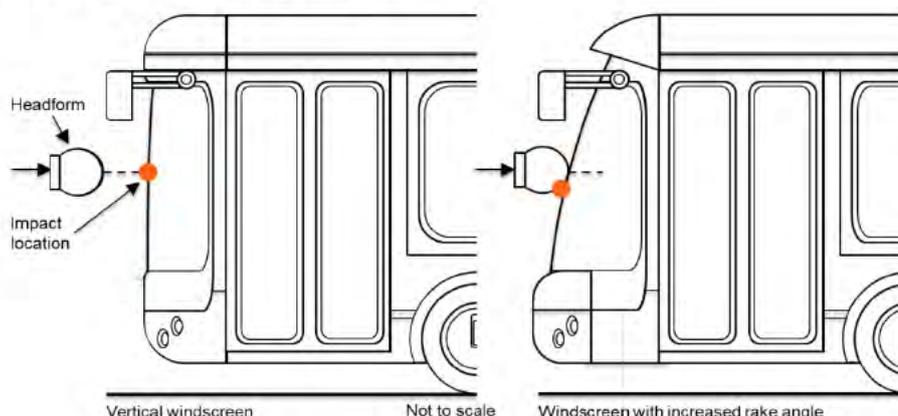

**Figure 61: Measuring point in the vertical longitudinal plane through the centre of the headform impactor**

3.20 **Maximum ride attitude** - means the vehicle positioned on a flat horizontal surface with its mass in running order, with the tyres inflated to

manufacturer recommended pressures, the front wheels in the straight-ahead position. The suspension shall be set in normal running condition as specified by the manufacturer for a speed of 40 km/h.

- 3.21 **Minimum ride attitude** - means the vehicle positioned on a flat horizontal surface (as per the maximum ride attitude, but) with its mass increased to gross vehicle mass; the maximum mass of the fully laden vehicle based on its construction and design performances, as declared by the manufacturer. This shall be less than or equal to the sum of the maximum axles' (group of axles) capacity. The suspension shall be set in the running condition for this condition as specified by the manufacturer for a speed of 40 km/h.
- 3.22 **Nominal ride attitude** - means the vehicle positioned at the mid-point of the maximum and minimum ride attitudes.
- 3.23 **Primary reference marks** - means holes, surfaces, marks and identification signs on the vehicle body. The type of reference mark used and the vertical (Z) position of each mark relative to the ground shall be specified by the vehicle manufacturer according to the running conditions specified along with the Minimum, Maximum and Nominal ride attitudes. These marks shall be selected so as to be able to easily check the vehicle front and rear ride heights and vehicle attitude.
- 3.24 **Side reference line** - means the geometric trace of the highest points of contact between a straight edge 700mm long and the sides of the vehicle, when the straight edge, held parallel to the transverse horizontal plane of the vehicle and inclined rearwards by [60°], is traversed rearwards, and maintains contact with the sides of the bus front end (Figure 62).

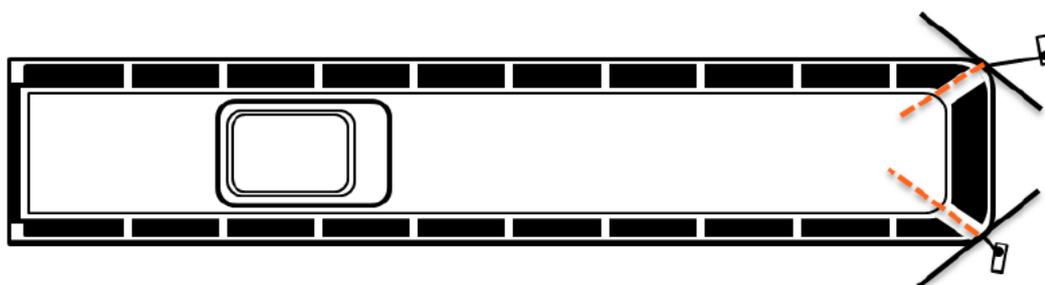
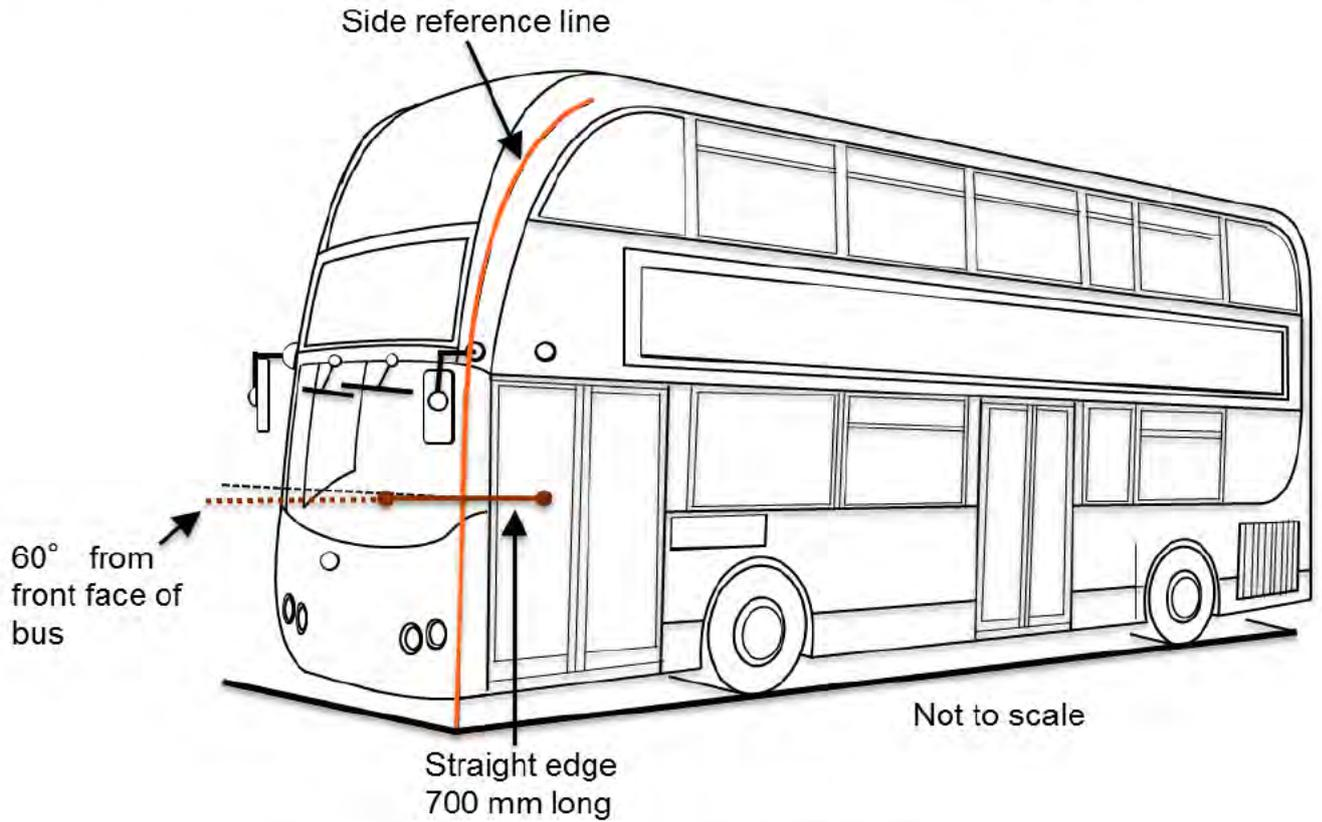
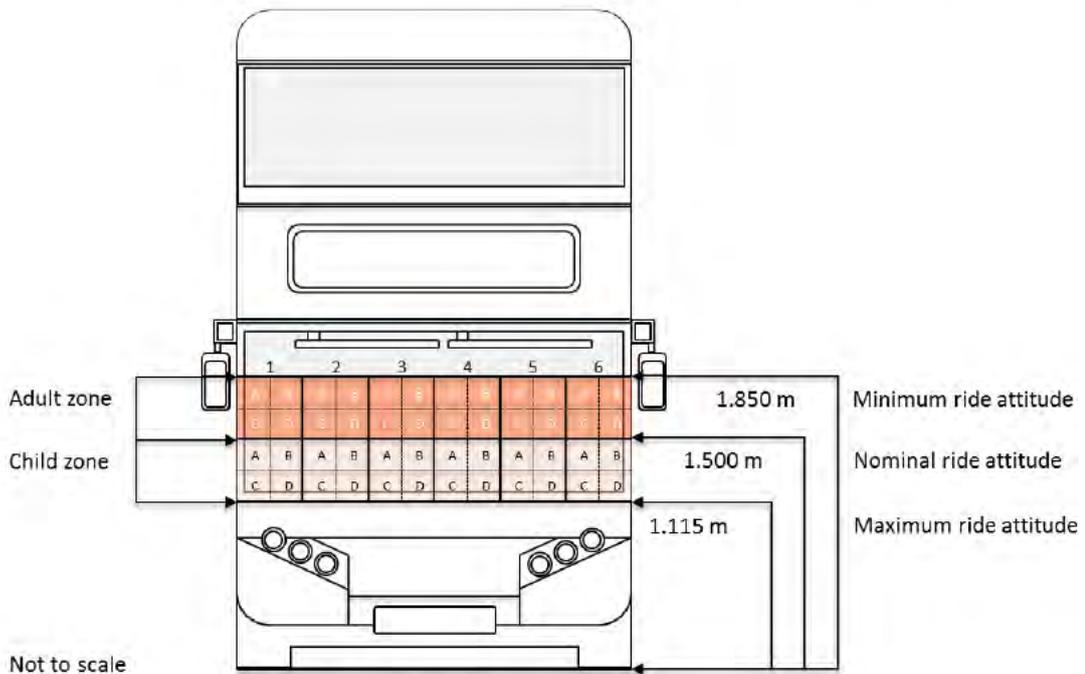

Figure 62a: Side reference line – plan view



**Figure 2b: Side reference line – front/side view**

3.25 **Test zones** - Both the child and adult headform test areas shall be divided into six test zones labelled A1, A2, ... C5, C6 with each of these test zones further sub-divided into four sub-sections labelled A-D (Figure 63).



**Figure 63: Labelling of test zones**



- 3.26 **Unladen vehicle mass** - means the nominal mass of a complete vehicle as determined by the following criteria:
- 3.26.1 Mass of the vehicle with bodywork and all factory fitted equipment, electrical and auxiliary equipment for normal operation of the vehicle, including liquids, tools, fire extinguisher, standard spare parts, chocks and spare wheel, if fitted.
- 3.26.2 The fuel tank shall be filled to at least 90 per cent of rated capacity and the other liquid containing systems (except those used for water) to 100 per cent of the capacity specified by the manufacturer.
- 3.27 **Vehicle type with regard to the pedestrian protection requirements** - means a category of vehicles with front end designs which, forward of the side reference lines, do not differ in such essential respects as:
- a) The structure,
  - b) The main dimensions,
  - c) The materials of the outer surfaces of the vehicle,
  - d) The component arrangement (external or internal),
- 3.27.1 in so far as they may be considered to have a negative effect on the results of the impact tests prescribed in this Regulation.
- 3.28 **Windscreen** - means the frontal glazing of the vehicle.
- 3.29 **Wrap Around Distance (WAD)** - means the geometric trace described on the outer surface of the bus front end by one end of a flexible tape, when it is held in a vertical longitudinal plane of the vehicle and traversed across the bus front end. The tape is held taut throughout the operation with one end held at the same level as the ground reference plane, vertically below the front face of the bumper and the other end held in contact with the front structure (see Figure 64). The vehicle shall be either positioned in the maximum, minimum or nominal ride attitudes.
- This procedure shall be followed, using alternative tapes of appropriate lengths, to describe wrap around distances of [1,115] mm (WAD1115), of [1,500] mm (WAD1500) and of [1,850] mm (WAD1850).

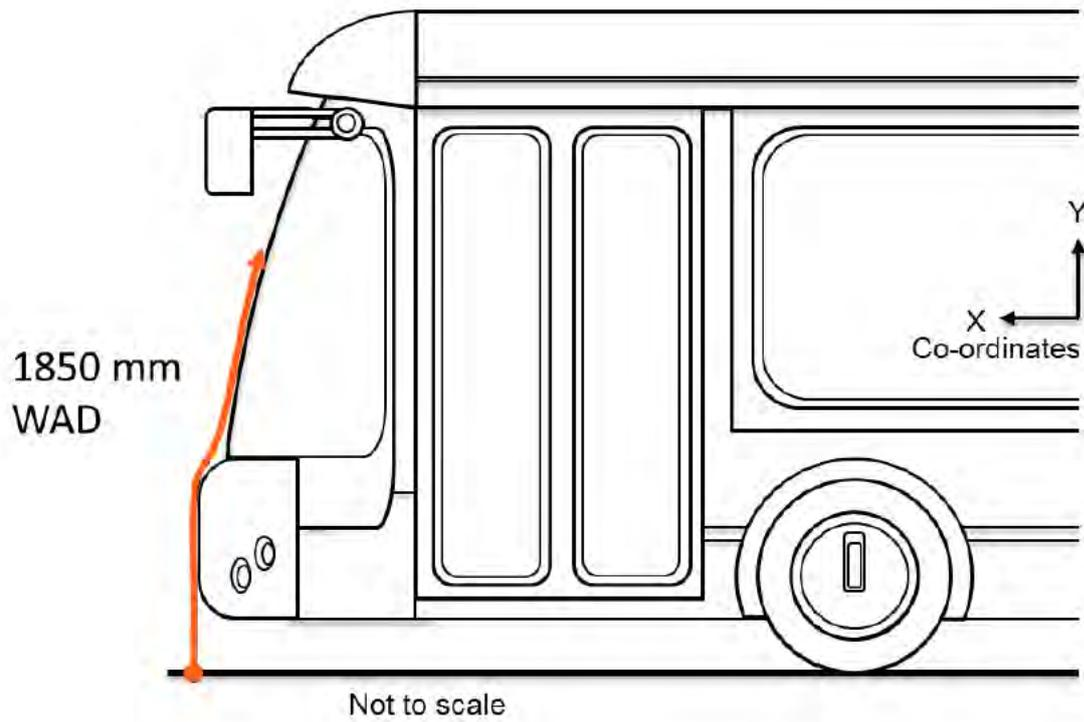

**Figure 64: Wrap around distance measurement**



## 4 Specifications

### 4.1 Minimum requirements

4.1.1 When tested in accordance with the test procedures in Section 5, all recorded HIC15 values shall not exceed [1,300].

4.1.2 In addition, the Bus VRU Impact Test Performance Score (BITS) (as defined in Section 4.3) must be, at least [25%].

### 4.2 Manufacturer selected points

4.2.1 The manufacturer may select up to three test points across both test areas to be retested. A supplementary test may then be performed to a different measuring point selected by the manufacturer within the same test zone (i.e. testing different sub-sections in the same test zone is permitted). The results from these supplementary tests will be averaged with the first result when used in the following rating system.

4.2.2 Example:

- a) First test results in HIC = 1250
- b) Manufacturer elected retest results in HIC = 700
- c) Mean HIC = 975

### 4.3 Bus VRU impact test performance scores (BITS)

4.3.1 The bus VRU impact performance score (BITS) shall be calculated for the bus front end using the following approach:

4.3.2 HIC15 values shall be converted to points using the following scale:

- a)  $HIC < 700$  = 2 points
- b)  $700 \leq HIC < 1000$  = 1 point
- c)  $HIC \geq 1000$  = 0 points

4.3.3 The total points score shall be divided by 24 to give a value between 0% and 100%.



## 5 Test procedure

- 5.1 When performing measurements:
- 5.1.1 If the vehicle is fitted with a badge, mascot or other structure, which would bend back or retract under an applied load of maximum 100N, then this load shall be applied before and/or while these measurements are taken.
  - 5.1.2 Any vehicle component which could change shape or position, other than suspension components or active devices to protect pedestrians, shall be set to their stowed position.
- 5.2 Impact tests
- 5.2.1 For all impact tests, the headform impactors shall meet the specifications provided in Appendix A and be certified pursuant to Appendix B. General testing conditions shall be provided pursuant to Appendix C, whilst common testing procedures are provided in Appendix D.
  - 5.2.2 Tests shall be made to the bus front end within the boundaries, as defined in Section 3 of this protocol.
  - 5.2.3 A minimum of six tests shall be carried out with the child headform impactor, one test to each of the six child test zones within the child headform test area (as defined in Section 3 of this protocol), at positions judged to be the most likely to cause injury.
  - 5.2.4 A minimum of six tests shall be carried out with the adult headform impactor, one test to each of the six adult test zones within the adult headform test area (as defined in Section 3 of this protocol), at positions judged to be the most likely to cause injury.
  - 5.2.5 Tests shall be to different types of structure, where these vary throughout the area to be assessed.
  - 5.2.6 Any parts damaged by an impact must be replaced before carrying out the next test.
  - 5.2.7 The selected measuring points for the child and adult headform impactors shall be a minimum of 165mm apart.
  - 5.2.8 These minimum distances are to be set with a flexible tape held tautly along the outer surface of the vehicle.
  - 5.2.9 No measuring point shall be located so that the impactor will impact the test area with a glancing blow resulting in a more severe second impact outside the test area.
  - 5.2.10 For all child and adult headform tests, a vertical and lateral impact location tolerance of  $\pm 10\text{mm}$  shall apply. This tolerance is measured along the surface of the vehicle front. The test laboratory may verify, at a sufficient number of measuring points, that this condition can be met and the tests are thus being conducted with the necessary accuracy.
  - 5.2.11 The headform velocity at the time of impact shall be either [6.94]  $\pm 0.2\text{m/s}$  or [11.11]  $\pm 0.2\text{m/s}$ . The speed shall be selected at random, with the constraint that at least half of the tests must be conducted at the 11.11



±0.2m/s velocity. Supplementary tests shall always be performed at the same headform velocity as the first test.

- 5.2.12 The direction of impact shall be perpendicular to the lateral vertical plane of the vehicle to be tested.



## 6 Test Report

- 6.1 The Test Service shall provide a comprehensive Test Report that will be made available to TfL. The test report shall consist of three distinct sections:
- a) Reference information
  - b) Confirmation of protocol compliance
  - c) Performance data
- 6.2 Reference information
- 6.2.1 As a minimum, the Test Service shall provide reference information including:
- d) Make (trade name of manufacturer);
  - e) Model/Type;
  - f) Commercial name(s) (if available);
  - g) Means of identification of type, if marked on the vehicle;
  - h) Location of that marking;
  - i) Variant (if applicable);
  - j) Category of vehicle;
  - k) Name and address of manufacturer;
  - l) Name(s) and address(es) of assembly plant(s);
  - m) Name and address of the manufacturer's representative (if any);
  - n) General construction characteristics of the vehicle;
  - o) Photographs and/or drawings of a representative vehicle;
  - p) Bodywork;
  - q) Type of bodywork;
  - r) Materials used and methods of construction;
  - s) Running order information;
  - t) Pedestrian protection;
  - u) A detailed description, including photographs and/or drawings, of the vehicle with respect to the structure, the dimensions, the relevant reference lines and the constituent materials of the frontal part of the vehicle (interior and exterior) shall be provided.
- 6.3 Confirmation of protocol compliance
- 6.3.1 Predominantly this item will relate to providing a description of testing completed.
- 6.3.2 The positions tested by the laboratories shall be indicated in the test report. The quadrant of each zone shall be noted as well as specific descriptions of the structures contacted.



- 6.3.3 Photographs should identify the test site before and after each test.
- 6.3.4 Records should be kept of the components changed between tests due to damage.
- 6.4 Performance data
  - 6.4.1 Every test shall be reported along with the corresponding HIC15 value.
  - 6.4.2 Furthermore, the BITS score associated with each result shall be recorded as well as the overall BITS score for the bus (Table 43 provides a blank example of a results table).
  - 6.4.3 The BITS scores should also be presented visually. Such images shall be colour coded to distinguish between the tests receiving 0, 1 or 2 points. A legend to the colour coding shall be provided within the Test Report. A hypothetical example is shown in Figure 65.

**Table 43: Example table for reporting of results**

Test site	Quadrant tested	HIC <sub>15</sub>	BITS score (%)
A1	A, B, C or D	XXX	YY
A2			
A3			
A3 (manufacturer elected retest)			
A4			
A5			
A6			
C1			
C2			
C3			
C4			
C5			
C6			
<b>Total</b>			

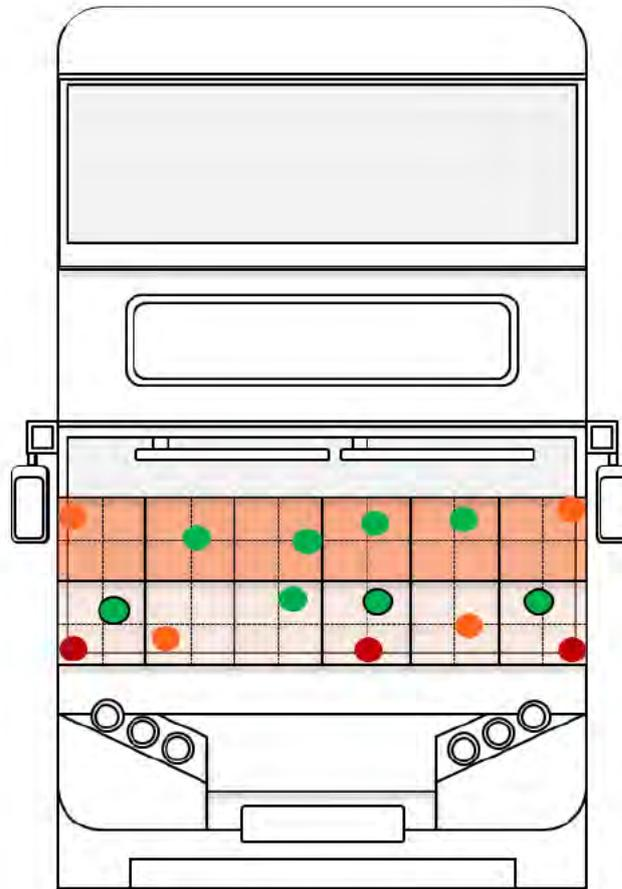

Not to scale

**Figure 65: Example image showing test results from Bus VRU Impact Test Standard (BITS)**

## Annex 1 Test impactor specifications

The specifications for the test impactors are taken from the international pedestrian safety regulations for passenger cars and car-derived vans which also use these impactors. In particular, these specifications feature within UN Regulation No. 127.

### 1 Child and adult headform impactors

The child headform impactor (Figure 66) shall be made of aluminium, be of homogenous construction and be of spherical shape. The overall diameter shall be 165mm  $\pm$ 1mm. The mass shall be 3.5kg  $\pm$ 0.07kg. The moment of inertia about an axis through the centre of gravity and perpendicular to the direction of impact shall be within the range of 0.008 to 0.012kgm<sup>2</sup>. The centre of gravity of the headform impactor including instrumentation shall be located in the geometric centre of the sphere with a tolerance of  $\pm$ 2mm.

- The sphere shall be covered with a 14mm  $\pm$ 0.5mm thick synthetic skin, which shall cover at least half of the sphere.
- The first natural frequency of the child headform impactor shall be over 5,000Hz.

### 2 Child headform instrumentation

A recess in the sphere shall allow for mounting one triaxial or three uniaxial accelerometers within  $\pm$ 10mm seismic mass location tolerance from the centre of the sphere for the measurement axis, and  $\pm$ 1mm seismic mass location tolerance from the centre of the sphere for the perpendicular direction to the measurement axis.

If three uniaxial accelerometers are used, one of the accelerometers shall have its sensitive axis perpendicular to the mounting face A (Figure 66) and its seismic mass shall be positioned within a cylindrical tolerance field of 1mm radius and 20mm length. The centre line of the tolerance field shall run perpendicular to the mounting face and its mid-point shall coincide with the centre of the sphere of the headform impactor.

The remaining accelerometers shall have their sensitive axes perpendicular to each other and parallel to the mounting face A and their seismic mass shall be positioned within a spherical tolerance field of 10mm radius. The centre of the tolerance field shall coincide with the centre of the sphere of the headform impactor.

The instrumentation response value CFC, as defined in ISO 6487:2002, shall be 1,000. The CAC response value, as defined in ISO 6487:2002, shall be 500g for the acceleration.

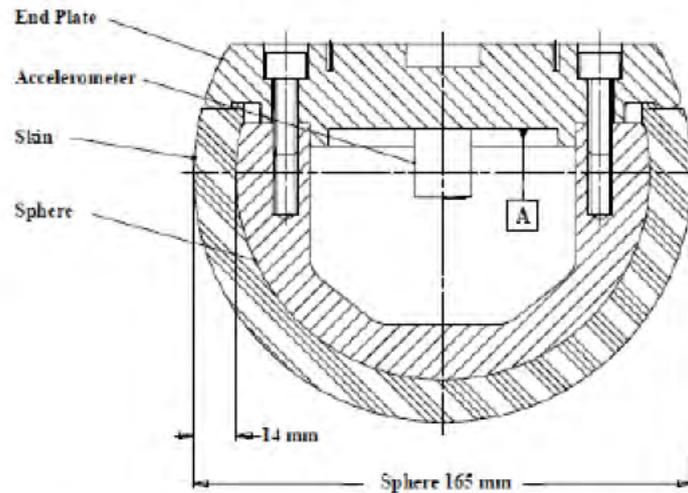
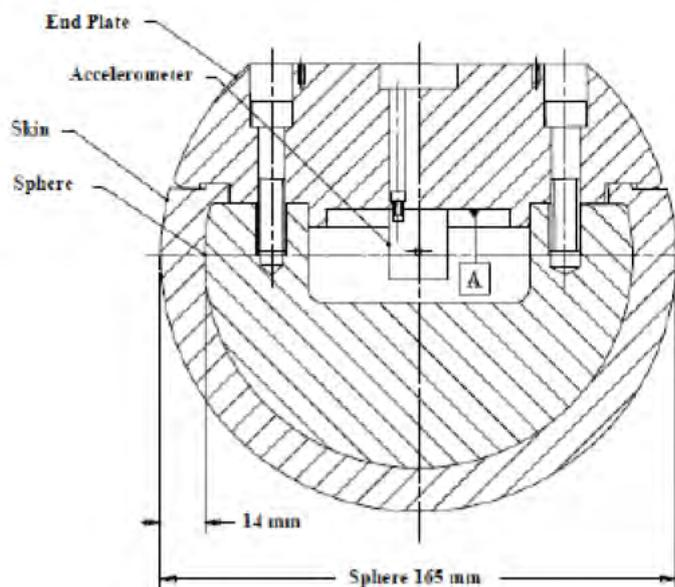

**Figure 66: Child headform impactor**

### 3 Adult headform impactor

The adult headform impactor (Figure 67) shall be made of aluminium, be of homogenous construction and be of spherical shape. The overall diameter is 165mm  $\pm$ 1 mm as shown in Figure 67. The mass shall be 4.5kg  $\pm$ 0.1kg. The moment of inertia about an axis through the centre of gravity and perpendicular to the direction of impact shall be within the range of 0.010 to 0.013kgm<sup>2</sup>. The centre of gravity of the headform impactor including instrumentation shall be located in the geometric centre of the sphere with a tolerance of  $\pm$ 5mm.

- The sphere shall be covered with a 14mm  $\pm$ 0.5mm thick synthetic skin, which shall cover at least half of the sphere.
- The first natural frequency of the headform impactor shall be over 5,000Hz.



**Figure 67: Adult headform impactor**



## **4 Adult headform instrumentation**

A recess in the sphere shall allow for mounting one triaxial or three uniaxial accelerometers within  $\pm 10\text{mm}$  seismic mass location tolerance from the centre of the sphere for the measurement axis, and  $\pm 1\text{mm}$  seismic mass location tolerance from the centre of the sphere for the perpendicular direction to the measurement axis.

If three uniaxial accelerometers are used, one of the accelerometers shall have its sensitive axis perpendicular to the mounting face A (see Figure 67) and its seismic mass shall be positioned within a cylindrical tolerance field of 1mm radius and 20mm length. The centre line of the tolerance field shall run perpendicular to the mounting face and its mid-point shall coincide with the centre of the sphere of the headform impactor.

The remaining accelerometers shall have their sensitive axes perpendicular to each other and parallel to the mounting face A and their seismic mass shall be positioned within a spherical tolerance field of 10mm radius. The centre of the tolerance field shall coincide with the centre of the sphere of the headform impactor.

The instrumentation response value CFC, as defined in ISO 6487:2002, shall be 1,000. The CAC response value, as defined in ISO 6487:2002, shall be 500g for the acceleration.

## **5 Rear face of the child and adult headform impactors**

A rear flat face shall be provided on the outer surface of the headform impactors which is perpendicular to the direction of travel, and typically perpendicular to the axis of one of the accelerometers as well as being a flat plate capable of providing for access to the accelerometers and an attachment point for the propulsion system.

## Annex 2 Certification of the impactor

The specifications for the certification of the test impactors are taken from the international pedestrian safety regulations for passenger cars and car-derived vans which also use these impactors. In particular, these specifications feature within UN Regulation No. 127.

### 1 Child and adult headform

The certified impactors may be used for a maximum of 20 impacts before re-certification. The impactors shall be re-certified if more than one year has elapsed since the previous certification or if the transducer output, in any impact, has exceeded the specified CAC.

When the headform impactors are dropped from a height of 376mm  $\pm$ 1mm in accordance with the conditions described below, the peak resultant acceleration measured by one triaxial (or three uniaxial) accelerometer (accelerometers) in the headform impactor shall be:

- a) For the child headform impactor not less than 245g and not more than 300g;
- b) For the adult headform impactor not less than 225g and not more than 275g.

The acceleration time curve shall be uni-modal.

The instrumentation response values CFC and CAC for each accelerometer shall be 1,000Hz and 500g respectively as defined in ISO 6487:2002.

The headform impactors shall have a temperature of 20  $\pm$ 2°C at the time of impact. The temperature tolerances shall apply at a relative humidity of 40  $\pm$ 30 per cent after a soak period of at least four hours prior to their application in a test.

### 2 Test procedure

The headform impactor shall be suspended from a drop rig as shown in Figure 68.

The headform impactor shall be dropped from the specified height by means that ensure instant release onto a rigidly supported flat horizontal steel plate, over 50mm thick and over 300mm x 300mm square which has a clean dry surface and a surface finish of between 0.2 and 2.0 micrometer.

The headform impactor shall be dropped with the rear face of the impactor horizontal and parallel with the impact surface. The suspension of the headform impactor shall be such that it does not rotate during the fall.

The drop test shall be performed three times.

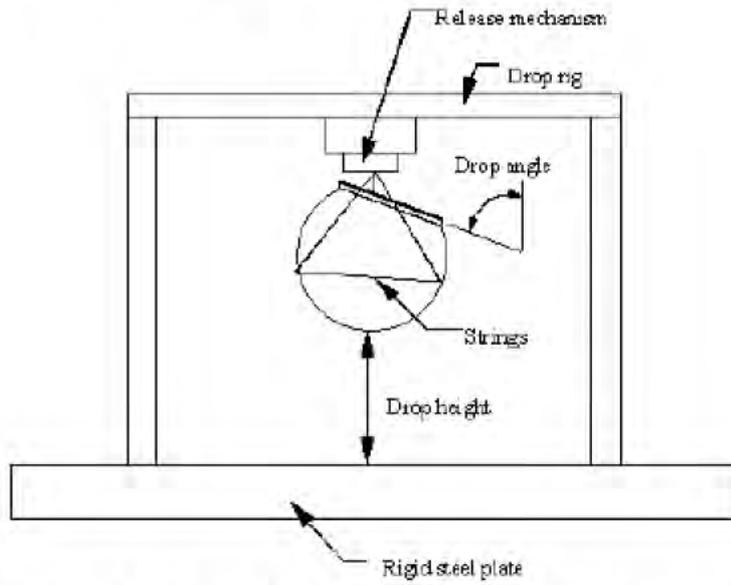

**Figure 68: Test set-up for dynamic headform impactor certification test**



## Annex 3      **General test conditions**

### **1      Temperature and humidity**

At the time of testing, the test facility and the vehicle or sub-system shall have a relative humidity of 40 per cent  $\pm$ 30 per cent and stabilized temperature of 20°C  $\pm$ 4°C.

### **2      Impact test site**

The test site shall consist of a flat, smooth and hard surface with a slope not exceeding 1 per cent.

### **3      Preparation of the vehicle**

Either a complete vehicle, or a cut-body, adjusted to the following conditions shall be used for the test.

- The vehicle shall be in either its maximum, minimum or nominal ride attitude, and shall be either securely mounted on raised supports or at rest on a flat horizontal surface with the parking brake applied.
- The cut-body shall include, in the test, all parts of the bus front end, all under-bonnet components and all components behind the windscreen that may be involved in a frontal impact with a vulnerable road user, to demonstrate the performance and interactions of all the contributory vehicle components. The cut-body shall be securely mounted in the maximum, minimum or nominal vehicle ride attitude.

All devices designed to protect vulnerable road users when impacted by the vehicle shall be correctly activated before and/or be active during the relevant test. It shall be the responsibility of the manufacturer to show that any devices will act as intended in a pedestrian impact.

For vehicle components which could change shape or position, other than active devices to protect pedestrians, and which have more than one fixed shape or position shall require the vehicle to comply with the components in each fixed shape or position.



## Annex 4      **Common test specifications**

### **1      Propulsion of the headform impactors**

The headform impactors shall be in “free flight” at the moment of impact, at the required impact velocity and the required direction of impact.

The impactors shall be released to “free flight” at such a distance from the vehicle that the test results are not influenced by contact of the impactor with the propulsion system during rebound of the impactor.

### **2      Measurement of impact velocity**

The velocity of the headform impactor shall be measured at some point during the free flight before impact, in accordance with the method specified in ISO 3784:1976. The measured velocity shall be adjusted considering all factors which may affect the impactor between the point of measurement and the point of impact, in order to determine the velocity of the impactor at the time of impact. The angle of the velocity vector at the time of impact shall be calculated or measured.

### **3      Recording**

The acceleration time histories shall be recorded, and HIC shall be calculated. The measuring point on the bus front end shall be recorded. Recording of test results shall be in accordance with ISO 6487:2002.



# Attachment 37: Bus Impact Test

## Standard Guidance Notes

---

### 1 Introduction

Bus fronts have been identified as one of the key contact causing parts of the vehicle in collisions with Vulnerable Road Users (VRU). Therefore, all bus front ends, in the region of potential head contacts, are required to have a construction that absorbs energy and protects VRUs in the event of a contact at that location on the vehicle.

As such, all buses shall have their VRU impact testing performance assessed against the associated VRU impact testing protocol. All buses shall have front ends which are energy absorbing or sufficiently compliant or frangible to meet the performance requirements.

This document sets out the guidance notes related to the assessment of VRU impact performance. These guidance notes are aimed at bus operators and manufacturers as a practical guide for implementation of the Bus Safety Standard.

These notes are for guidance only, and are not legally binding. In all circumstances, the guidance provided by a manufacturer of the bus or system shall take precedence, and these guidance notes are only for use in the absence of other information. These are not intended to be exhaustive, but to point the operators toward practical advice and questions to raise with manufacturers/suppliers.

### 2 Procedure background

Test procedures for the assessment of the structural interaction between passenger cars and pedestrians exist, both for type approval purposes (UN Regulation No. 127 and UN GTR No. 9) and for use in consumer assessment ratings of vehicles (e.g. Euro NCAP). These existing protocols have been used as a basis for the development of a test procedure for the assessment of the protection for Vulnerable Road Users (VRU) in impacts with buses. This procedure extends that already developed within the Aprosys Project for Heavy Goods Vehicles.

#### 2.1 Vehicle preparation and marking

The protocol specifies the marking out of the front of the vehicle into two zones, one an adult zone, and the other a child zone. The adult zone is the area where the head of an adult pedestrian is likely to hit and the child zone is the equivalent area for a child pedestrian. The marking procedure includes allowances for changes in ride height of the vehicle and defines the “corners” of the vehicle at either side. The lower boundary of the test zone is defined with the vehicle at its normal ride height, and the upper boundary with the vehicle at its minimum ride height. The heights of the boundaries are defined based on anthropometric data, with the maximum boundary height of 1850 mm relating to the height of a 95<sup>th</sup> percentile adult male and the

minimum boundary height of 1115 mm relating to the height of a 5<sup>th</sup> percentile 6 year old. Figure 69 shows the marking of the two test zones.

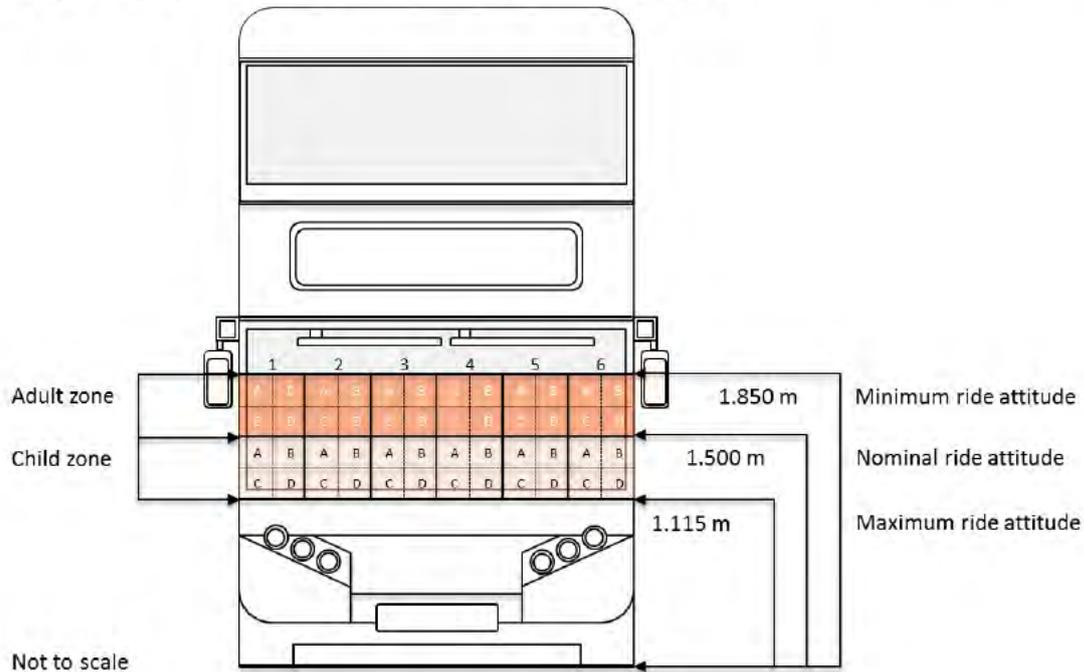

**Figure 69: Marking out of test zones**

Both the child and adult test zones are divided horizontally into six areas and labelled A1, A2.....C5, C6 as shown in Figure 63. Each area is then sub-divided into quarters.

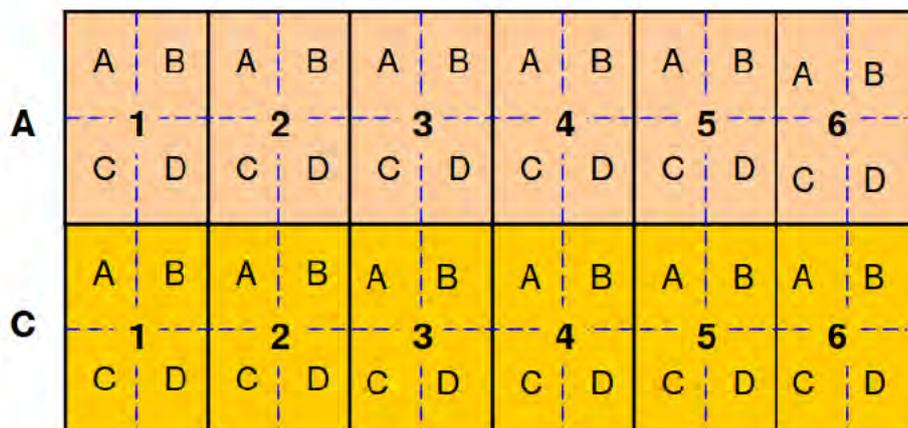

**Figure 70: Labelling of test zones**



### 2.1.1 Impact points

The test points are selected by the test engineer from the testing organisation (as is the case in EuroNCAP pedestrian testing of passenger cars and regulatory testing). One point must be selected from each test zone (A1, A2.....C5, C6). The test point selected should be expected to be the most injurious within that zone. In some cases, multiple test zones can cover the same structure, which is expected to have equivalent performance (e.g. the windscreen).

The vehicle manufacturer may specify up to three additional tests (one per test zone), allowing for a total maximum of 15 tests.

### 2.1.2 Testing

The testing is carried out with air, spring or hydraulically propelled headforms. The protocol provides details of how to position the headform. The headform is propelled at the vehicle in the x-direction parallel to the longitudinal axis of the vehicle (nominally this is normal to the surface).

The testing is carried out using an adult headform and a child headform for the respective test areas. The prime test speed used is  $11.1 \pm 0.2\text{m/s}$ . A second speed of  $[8.3 \pm 0.2\text{m/s}]$  will be used in addition for at least one of the test points in each zone. These lower speed tests will be selected at random from the proposed matrix of tests.

To avoid repeated testing of the same parts, no two tests may be carried out in the same quarter of each zone. Furthermore, no two tests are allowed within 165 mm (an adult head/headform diameter).

## 2.2 Assessment criteria

The 15ms Head Injury Criteria ( $\text{HIC}_{15}$ ) is used for the assessment of the structural aggressivity. For each test location, up to two points can be awarded, based on the performance criteria shown below (and in the protocol). The scores for each test zone are combined to give a total out of 24. This is then scaled to a maximum score of 100% (divided by 24, multiplied by 100%).

Performance criteria.

- $[\text{HIC} < 700 \quad = 2 \text{ points (Green)}$
- $700 \leq \text{HIC} < 1,000 \quad = 1 \text{ point (Yellow)}$
- $1000 < \text{HIC} \quad = 0 \text{ points (Red)}$

A test failure would occur with a HIC value greater than 1300.

Also, all [new] buses shall meet the minimum bus VRU impact test performance score (BITS) requirement of [25%].

## 3 Selection of buses/systems



Any bus that meets the TfL Bus Vehicle Specification.

The VRU Impact Protection requirements may be assessed against a new build bus.

### 3.1 Compliance and warranty

A bus operator should ask to see a VRU Impact Performance test report from the bus manufacturer including the performance rating (a value between 0 and 1).

### 3.2 Interpreting the requirements and selecting the most effective way to fulfil them

The requirements relate to the energy-absorbing compliance or frangibility of the bus front end. In order to minimise the acceleration transmitted to the head of a vulnerable road user in the event of a collision, then the following elements should be avoided or minimised:

- **Sharp:** In accordance with the requirements of exterior projections, then sharp edges and features must be avoided on the outer surface of a vehicle (in locations where they may contact a vulnerable road user). Furthermore, tight radii tend to concentrate stiffness and hence should be avoided from the point of minimising the acceleration of a contacting head or headform.
- **Hard:** Wherever possible yielding structures should be provided to avoid hard transfers of momentum to the head
- **Heavily featured:** As mentioned under sharpness, transitions of features on a bus front end that involve changes in angle are likely to provide natural stiffness to the structure. Therefore, ideally any changes in profile throughout the head impact areas should be progressive, offering a relatively flat bending surface.
- **Robust:** One of the most important features for components such as windscreens is their ability to fracture during an impact. The onset of fracturing should be as early in the impact event as possible to gain full advantage of that energy-absorbing failure. For glazing this could be tuned through careful selection of thickness, composition of layers and potentially the manufacturing process, etc. Advice from windscreen manufacturers may need to be sought on compliance with regulated behaviour of screens and tuning impact performance.

In the first instance, the Bus Vehicle Specification (BVS) and associated impact test and assessment procedure recognises that current buses already have large flat glazed areas on the front of the vehicle which have useful frangible properties for head protection. It is expected that the minimum standard can be met with conventional design techniques. However, through the performance rating, it will recognise improvements over and above this minimum standard if further improvements and tuning of the front end structures can be provided.

### 3.3 Susceptibility to damage

Increasing the tendency for glazing to fracture will have an adverse consequence on the ability of a windscreen to be durable and resistant to damage. For this reason, the current levels of performance required to achieve a high impact performance rating score are conservative. The precise definitions have been set around



evidence of existing performance for bus fronts. However, if a technical solution can be provided that allows lower HIC test values without deteriorating maintenance costs and concerns and screen strength, then more stringent levels of performance could be encouraged.

### **3.4 Features sharing other functional requirements**

To ensure that the front end of a bus performs well in other crash and failure modes, then certain requirements are placed for there to be strong structural members within the broad VRU contact area. To demonstrate crash protection for bus drivers, UN Regulation 29 (with regard to the protection of the occupants of the cab of a commercial vehicle) has been used by some manufacturers. The need to meet these structural requirements must coexist with new requirements for VRU impact protection. Experience within the passenger car industry says that the two design goals are not mutually exclusive. Effective VRU protection is at such a different level of stiffness to other crashworthiness protection that both sets of parts must be designed to act in series (with the VRU protection being placed in front of harder components). The consequence of this is that sufficient clearance must be designed between the exterior surface and underlying hard parts to allow deformation and cushioning during a VRU collision. The conflicts over packaging are recognised in this regard, but based on the experience with existing design of bus front ends are not considered to be prohibitive. Careful tuning of stiffness within deformable elements (as with car bumpers and bonnets) will minimise the clearance necessary to meet the VRU impact performance requirements.

## **4 Training**

### **4.1 For test houses**

Test houses accredited to undertake approval tests to UN Regulation No. 127 or UN Regulation GTR No. 9 will be considered suitable to undertake performance tests. Test houses without such accreditation will be required to demonstrate to TfL at their expense that they can achieve the same standard of testing as an accredited organisation.



# **Attachment 38: Bus Front End Design**

## **– Minimum Geometric Requirements**

### **Guidance Notes**

#### **(Vulnerable Road User (VRU) Frontal Crashworthiness)**

---

## **1 Introduction**

Bus fronts have been identified as one of the key injury-causing contact areas of the vehicle in collisions with Vulnerable Road Users (VRU). Therefore, all bus front ends are required to have a geometric design that both improves protection for VRUs during the primary impact within a collision and reduces the risks of VRUs being run over subsequently.

As such, all buses new buses shall have a front end design that complies with the minimum bus front end geometry requirements for both vertical rake and horizontal curvature.

This document sets out the guidance notes related to the assessment of front end geometry and specifically, with respect to the minimum requirements. These guidance notes are aimed at bus operators and manufacturers as a practical guide for implementation of the Bus Safety Standard.

These notes are for guidance only, and are not legally binding. In all circumstances, the guidance provided by a manufacturer of the bus or system shall take precedence, and these guidance notes are only for use in the absence of other information. These are not intended to be exhaustive, but to point the operators toward practical advice and questions to raise with manufacturers/suppliers.

## **2 Selection of buses/systems**

All [new] buses shall have a front end geometry that complies with the minimum bus front end geometry requirements for both vertical rake angle and horizontal curvature. Therefore, selection can be any bus that meets the TfL Bus Vehicle Specification.

The minimum geometry requirements may be assessed against a new build bus. It is expected that compliant vehicles can already be selected from the models available currently.



## 2.1 Compliance and warranty

A bus operator should ask to see documentary evidence of compliance with the requirements. Compliance may be established through either a CAD-based approach or physical testing. Whichever approach is adopted, a dossier of inspection points and measurements should be provided to assure compliance.

## 2.2 Interpreting the requirements and selecting the most effective way to fulfil them

The minimum requirements are intended to dictate a progressive surface geometry for the bus front end, as necessary to bring about improvements in vulnerable road user protection. It is expected that the surface is broadly continuous in this regard. However, it is also recognised that necessarily features are incorporated in the bus front end for functional reasons and styling. Experience from the car industry suggests that small projections and protuberances can be used to provide localised areas of angled surfaces. The most effective vulnerable road user protection will be realised if the geometry requirements are adopted generally, the greater the angles and the size of the areas presenting that angle then the more effective the measure will be.

# 3 Training

## 3.1 For test houses

The nature of verifying compliance with the requirements will depend on whether it is demonstrated through CAD or physically.

For CAD assessments, appropriate sections should be cut to demonstrate bus front end geometry in a way that can be visualised against the requirements. Any inspection should be facilitated by applying tangents to the surface where the appropriate angles of rake or horizontal curvature can be viewed. It should be possible for the inspection to identify the worst angle throughout the section.

For physical inspections, vertical rake can be measured with an inclinometer. Here it should be noted that the footprint for the measurements should be 236 mm x 236 mm. Smaller features are exempt from the requirements.

Compliance with the horizontal angle requirements may be determined by application of a geometric gauge. This would be a device that pushes forward either,

- a 236 mm x 236 mm probe, with a horizontal angle of  $[15]^\circ \pm 0.5^\circ$  along the longitudinal axis of the vehicle and at a known offset from the most lateral aspect of the vehicle, or
- a rounded panel with horizontal curvature of  $>0.3$  m, again with a nominal face size of 236 mm x 236 mm.

Test houses undertaking approval tests to UN Regulation No. 127 or UN Regulation GTR No. 9 will already possess the capability to apply a 236 mm x 236 mm probe to the front of a car in order to determine the bumper corners. The difference with this application is that the horizontal angle is  $15^\circ$  instead of  $30^\circ$ .



## **4 Ongoing observations**

### **4.1 Glare and visual artefacts**

In discussions around these geometric requirements, two issues have been raised as potential disbenefits associated with the improvements for vulnerable road user protection. These are:

1. That the vertical rake of the windscreen may refract light from overhead sources (such as street lights and the sun) creating glare for the driver.
2. That the horizontal curvature of the windscreen may create apparitions or visual artefacts that distort direct vision for the driver, particularly towards the corners of the screen.

These minimum requirements do not take design envelopes for bus front end geometry beyond that of existing designs, therefore these potential issues are not perceived to be critical factors (otherwise we would already be aware of the problem). However, operators should be mindful of the potential and will be expected to log and feedback any potential issues, if substantiated reports become available.

# Attachment 39: Bus Front End Design

## – Enhanced Geometric Requirements

### Guidance Notes

#### (Vulnerable Road User (VRU) Frontal Crashworthiness)

---

## 1 Introduction

Bus fronts have been identified as one of the key injury-causing contact areas of the vehicle in collisions with Vulnerable Road Users (VRU). Therefore, all bus front ends are required to have a geometric design that both improves protection for VRUs during the primary impact within a collision and reduces the risks of VRUs being run over subsequently.

As such, all buses new buses shall have a front end design that complies with the minimum bus front end geometry requirements for both vertical rake and horizontal curvature.

This document sets out the guidance notes related to the assessment of front end geometry and specifically, with respect to the enhanced requirements. These guidance notes are aimed at bus operators and manufacturers as a practical guide for implementation of the Bus Safety Standard.

These notes are for guidance only, and are not legally binding. In all circumstances, the guidance provided by a manufacturer of the bus or system shall take precedence, and these guidance notes are only for use in the absence of other information. These are not intended to be exhaustive, but to point the operators toward practical advice and questions to raise with manufacturers/suppliers.

## 2 Selection of buses/systems

When implemented, all new buses shall have a front end geometry that complies with the enhanced bus front end geometry requirements for both vertical rake angle and horizontal curvature. Therefore, selection will be any bus that meets the TfL Bus Vehicle Specification.

The enhanced geometry requirements may be assessed against a new build bus. It is expected that existing designs will not be fully compliant. Therefore new build buses will be required before full compliance with these requirements can be demonstrated.



## 2.1 Compliance and warranty

A bus operator should ask to see documentary evidence of compliance with the requirements. Compliance may be established through either a CAD-based approach or physical testing. Whichever approach is adopted, a dossier of inspection points and measurements should be provided to assure compliance.

## 2.2 Interpreting the requirements and selecting the most effective way to fulfil them

At the enhanced level of geometry requirements, it may be possible that longer bus front ends are used to meet the design goals. This approach is not necessarily the only option, as an alternative (though an option with operational limitations) approach would be to reduce capacity instead.

Even with the enhanced requirements, the minimum scale of length difference necessitated to add curvature to the front end will be:

- Approximately 170 mm difference (versus a flat front end) in the longitudinal axis across whole front end due to vertical raking
- Approximately 294 mm difference (versus a flat front end) in the longitudinal axis at the centreline of the vehicle due to horizontal curvature.

The enhanced requirements are intended to dictate a progressive surface geometry for the bus front end, as necessary to bring about improvements in vulnerable road user protection. It is expected that the surface is broadly continuous in this regard. However, it is also recognised that necessary features are incorporated in the bus front end for functional reasons and styling. Experience from the car industry suggests that small projections and protuberances can be used to provide localised areas of angled surfaces. The most effective vulnerable road user protection will be realised if the geometry requirements are adopted generally, the greater the angles and the size of the areas presenting that angle then the more effective the measure will be.

Beyond this, it should be recognised that better VRU protection performance has been demonstrated in the modelling study parameter sweeps to be associated with greater curvature and raking. Therefore, maximising the rake and curvature would be preferential for VRU protection. Radical redesigns to bus front ends would be encouraged if VRU protection is considered in isolation. However, it should be kept in mind that extra rake or curvature has the likely effect of increasing further the vehicle length or reducing capacity.



If buses with enhanced geometry do indeed have an increased overall length (or perhaps a differing front overhang, then consideration will need to be given to:

- Door positions relative to the overall length of the vehicle

Note that the required distance between doors (as specified in UN Regulation No. 107) is defined as a percentage of the overall length of the passenger compartment.

- The turning circle of the vehicle

Again regulatory requirements will have to be maintained (as per Regulation (EU) No. 1230/2012 – Masses & Dimensions)

- Potential stabling of vehicles in capacity constrained depots

## **3 Training**

### **3.1 For test houses**

The nature of verifying compliance with the requirements will depend on whether it is demonstrated through CAD or physically.

For CAD assessments, appropriate sections should be cut to demonstrate bus front end geometry in a way that can be visualised against the requirements. Any inspection should be facilitated by applying tangents to the surface where the appropriate angles of rake or horizontal curvature can be viewed. It should be possible for the inspection to identify the worst angle throughout the section.

For physical inspections, vertical rake can be measured with an inclinometer. Here it should be noted that the footprint for the measurements should be 236 mm x 236 mm. Smaller features are exempt from the requirements.

Compliance with the horizontal angle requirements may be determined by application of a geometric gauge. This would be a device that pushes forward either,

- a 236 mm x 236 mm probe, with a horizontal angle of  $[15]^\circ \pm 0.5^\circ$ , along the longitudinal axis of the vehicle and at a known offset from the vehicle centreline, or
- a 236 mm x 236 mm probe, with a horizontal angle of  $[30]^\circ \pm 0.5^\circ$ , along the longitudinal axis of the vehicle and at a known offset from the most lateral aspect of the vehicle.

Test houses undertaking approval tests to UN Regulation No. 127 or UN Regulation GTR No. 9 will already possess the capability to apply a 236 mm x 236 mm probe to the front of a car in order to determine the bumper corners. The difference with this application is that the horizontal angle includes  $15^\circ$  as well as  $30^\circ$ .

### **3.2 Features sharing other functional requirements**

It is important to ensure that the front end of a bus performs well in other crash and failure modes, such as with other buses, HGVs and cars. This would require certain strong structural members within the broad VRU contact area. It is advised that protection in these other modes is considered at the same time as making the design



changes aimed at protecting the VRUs. This is needed to deliver protection to both the bus drivers and the VRUs.

One option is to use UN Regulation 29 (with regard to the protection of the occupants of the cab of a commercial vehicle), and this has already been used by some manufacturers. The geometry of category M3 buses is quite different to other vehicles, so the geometric and structural interactions with other vehicles must be carefully considered, and other tests may also be relevant. TfL is not yet making any requirements on this topic, but is recommending any new bus designs consider the interactions with a wide range of collision partners. For iterative, evolving designs this is unlikely to present a problem, but for those bus fronts designed with a substantially different front end geometry, then additional care should be taken over preserving safety for the driver and for ensuring crash compatibility for collisions with other road users.

## **4 Ongoing observations**

### **4.1 Glare and visual artefacts**

In discussions around these geometric requirements, two issues have been raised as potential disbenefits associated with the improvements for vulnerable road user protection. These are:

- That the vertical rake of the windscreen may refract light from overhead sources (such as street lights and the sun) creating glare for the driver.
- That the horizontal curvature of the windscreen may create apparitions or visual artefacts that distort direct vision for the driver, particularly towards the corners of the screen.

These enhanced requirements will take design envelopes for bus front end geometry beyond that of existing designs. Though unlikely, it is possible that the new designs are susceptible to these issues. Therefore, operators should be mindful of the potential and will be expected to log and feedback any potential issues, if substantiated reports become available.



# Attachment 40: Bus Front End Design – Wiper Protection Guidance Notes

## (Vulnerable Road User (VRU) Frontal Crashworthiness)

---

### 1 Introduction

Bus fronts have been identified as one of the key contact causing parts of the vehicle in collisions with Vulnerable Road Users (VRU). Therefore, all bus front ends, in the region of potential head contacts, are required to have a construction that absorbs energy and protects VRUs in the event of a contact at that location on the vehicle.

As such, all buses shall have their VRU impact testing performance assessed against the associated VRU impact testing protocol. All buses shall have front ends which are energy absorbing or sufficiently compliant or frangible to meet the performance requirements.

This document sets out the guidance notes related to the assessment of VRU Impact Performance in the specific aspect of windscreen wipers. These guidance notes are aimed at bus operators and manufacturers as a practical guide for implementation of the Bus Safety Standard.

These notes are for guidance only, and are not legally binding. In all circumstances, the guidance provided by a manufacturer of the bus or system shall take precedence, and these guidance notes are only for use in the absence of other information. These are not intended to be exhaustive, but to point the operators toward practical advice and questions to raise with manufacturers/suppliers.

### 2 Selection of buses/systems

Any bus that meets the TfL Bus Vehicle Specification.

The windscreen wiper requirements may be assessed against a new build bus.

#### 2.1 Compliance and warranty

A bus operator should ask to see one of two things from the bus manufacturer.

- a) A statement confirming that the windscreen wipers are mounted at a height greater than 2.0 m from the ground plane – making them exempt from impact testing
- b) If mounted at or below 2.0 m, a VRU Impact Performance test report confirming that when impacted at the worst case location, the head injury criterion (HIC<sub>15</sub>) value did not exceed [1,300].



## 2.2 **Interpreting the requirements and selecting the most effective way to fulfil them**

The most effective way of controlling head injury risk through potential contacts with the windscreen wipers is to move the mounting points out of the likely regions of the bus front end that may be contacted in a collision. Citing them above 2.0 m fulfils this requirement for most of the vulnerable road user population.

Another method of mitigating injury risk is to make the structures compliant, frangible or shielded by a protective element. The extent to which this has been achieved can be assessed practically through the impact test protocol. Assuming that the windscreen wiper is no more injurious than the surrounding region of the bus front end, then this secondary approach may be considered as an appropriate alternative to repositioning the wiper mounting points.

## 2.3 **Direct vision**

If the windscreen wiper mounting points have been altered between bus design iterations, then care must be taken to ensure that the swept area of the windscreen is at least maintained. This must still be compliant with direct vision requirements.

## 2.4 **Indirect vision**

The nearside mirror of a bus may be visible to the driver though the swept area of the windscreen. If this is the design philosophy adopted by a manufacturer, then this requirement should be preserved.

# 3 **Training**

## 3.1 **For test houses**

Test houses accredited to undertake approval tests to UN Regulation No. 127 or UN Regulation GTR No. 9 will be considered suitable to undertake performance tests. Test houses without such accreditation will be required to demonstrate to TfL at their expense that they can achieve the same standard of testing as an accredited organisation.

## 3.2 **Bus maintenance engineers**

The engineers carrying out general bus maintenance should be aware that access to the windscreen wipers may be more difficult with them mounted at more than 2.0 m from the ground. This is considered to be a minor effect.